



Dental Treatment Unit

# Signo T500

System display panel

## Operation Instructions



Thank you very much for purchasing the Signo T500.

Be sure to read these operation instructions completely and observe the method of use and precautions before use in order to fully utilize the functions of this equipment, to use it effectively, and to use it safely and without harm to people.

Read this operation instructions carefully before use. Keep the operation instructions close to this unit for future reference.

■ Trademarks and registered trademarks

The names of companies, products, services etc. listed in these operation instructions are the trademarks or registered trademarks of the respective companies.

# Contents

■ Introduction	6
■ 1 Installation	8
1.1 Installation	8
1.2 Preparation	8
1.3 Connection of Instruments	9
1.4 Installation of Filters	9
■ 2 Part Names	10
2.1 Chair Type	10
2.2 Tray Type	12
2.3 Foot control	14
2.4 Accessories	15

<b>■ 3 Actions Before and After Use</b>	<b>16</b>
3.1 Preparation Before Use	16
3.1.1 Water/Air Supply and Main Switch	16
3.2 Interruption/Completion of Use	17
3.3 Storage	18
<b>■ 4 Method of Operation</b>	<b>19</b>
4.1 Precautions When Operating the Chair	20
4.1.1 Precautions When Operating the Chair	20
4.1.2 Safety Switch	21
4.2 Operation Panel	23
4.2.1 Display Panel	23
4.2.2 Assistant-side Operation Panel	25
4.3 Chair	26
4.3.1 Manual Chair Operation	26
4.3.2 Automatic Movement of Chair	27
4.3.3 Cordless Foot Control	31
4.3.4 Headrest Height and Angle Adjustment	32
4.3.5 Backrest Height Adjustment	34
4.3.6 Armrest	35
4.4 Tray	36
4.4.1 Tray	36
4.4.2 Over-the-Patient Tray Type/Floor-mounted Tray Type	38
4.4.3 Cart	41
4.4.4 Auxiliary Tray	41
4.5 Instrument Holder	42
4.5.1 Doctor-side Holder	42
4.5.2 Assistant-side Holder	43
4.6 Instruments	46
4.6.1 Water Tank	46
4.6.2 Water Supply Rate Adjustment	47
4.6.3 Foot Control Operation (extended function)	48
4.6.4 Common Settings for Instruments	49
4.6.5 Air Turbine Handpiece	50

4.6.6 Micromotor	53
4.6.7 Threeway Syringe	58
4.6.8 Vacuum Syringe	62
4.6.9 Saliva Ejector	64
4.6.10 Ultrasonic Scaler (Newtron)	65
4.6.11 Ultrasonic Scaler (Solfy)	69
4.7 Unit	72
4.7.1 Part Names	72
4.7.2 Warmer	74
4.7.3 One-touch Connectors (water supply/air supply)	75
4.8 Basin	77
4.8.1 Basic Operation	77
4.8.2 Cup Water Supply	79
4.9 Operating Light	80
4.9.1 Basic Operation	80
4.9.2 Setting	82
4.10 Other Settings	83
4.10.1 Countdown Timer	83
4.10.2 Display while Instruments are in Holders	87
4.10.3 Show Display in PC Monitor	91
4.10.4 Common Settings	92
4.10.5 Individual User Settings	97

## ■ 5 Caring for the Unit 110

5.1 Autoclave Sterilization	110
5.1.1 Instrument Sterilization	111
5.1.2 Holder Cup Sterilization	112
5.1.3 Other Sterilization	115
5.2 Wiping with Disinfectant Ethanol	116
5.2.1 Instrument Wiping	116
5.2.2 Wiping the Leather Seat	117
5.2.3 Wiping Other Parts	118
5.3 Other Cleaning Methods	119
5.4 Everyday Maintenance (before treatment)	120
5.4.1 Flushing of Residual Water	120

5.5 Everyday Maintenance (between patients).....	125
5.5.1 Vacuum System Rinsing.....	125
5.5.2 Automatic Rinsing of Vacuum Tank.....	127
5.6 Everyday Maintenance (after use).....	128
5.6.1 Cleaning the Vacuum Filter.....	128
5.6.2 Cleaning the Basin.....	129
5.6.3 Vacuum Syringe Disassembly and Cleaning.....	131
5.6.4 Disassembly and Cleaning the Saliva Ejector.....	133
5.7 Monthly Maintenance.....	135
5.7.1 Cleaning the Water Supply Tank.....	135
5.7.2 Checking and Cleaning the Vacuum Tank.....	136
5.7.3 Amalgam separator.....	138
5.7.4 Spittoon Valve.....	139
5.7.5 Cleaning Inside the Drain Trap.....	140
5.7.6 Cleaning the Oil Collector.....	142
5.8 Annual Maintenance.....	143
5.8.1 Sterapore Cartridge Replacement.....	143
5.9 Maintenance as Required.....	147
5.9.1 Cleaning the Automatic Filler.....	147
5.9.2 Cleaning Other Parts.....	147

## ■ 6 Maintenance and Inspection 148

6.1 Replacement of Consumable Parts.....	148
6.1.1 Replacement of Consumable Parts.....	149
6.2.1 Parts Replacement for Threeway Syringe.....	151
6.2 Daily Inspection by the User.....	152
6.2.1 Startup Inspection.....	152
6.2.2 Shutdown Inspection.....	152
6.3 Regular Maintenance Inspection.....	153
6.3.1 Maintenance and Inspection by the User.....	153
6.3.2 Outsourcing Maintenance and Inspection to a Contractor.....	154
6.4 After-sales Service and Contact Information.....	154

---

<b>7 If Problems Arise</b>	<b>155</b>
7.1 Items to be Checked before Requesting Repair	155
7.2 Error Display	156
7.3 Fuse	157
<b>8 Warranty and Repair</b>	<b>158</b>
8.1 Warranty of this Product	158
8.2 Warranty Card	158
8.3 Repair	159
8.3.1 Before Requesting a Repair	159
8.3.2 Requesting a Repair	159
8.3.3 Spare Part Maintenance Period	159
<b>9 Disposal of the Medical Device</b>	<b>160</b>
9.1 Disposal of This Product	160
<b>10 General Information</b>	<b>161</b>
10.1 Specifications	161
10.2 Symbols	162
10.3 EMC Electromagnetic Compatibility	163

# Introduction

## To our Customers

Please be sure to receive a full explanation of how to handle each item based on the operation instructions supplied with the product.

After confirmation, fill in the Warranty Card with the clinic name, address and telephone number, sign it and provide the dealer with a copy.

## To Dealers

After completion of installation, explain to the doctor how to deal with the various items of the unit to ensure safety, in accordance with these operation instructions.







After the explanation, ask the doctor to fill out the name, address and telephone number fields on the Warranty Card and to sign it, then add your own name and give the card back to the doctor. A copy of the warranty card (manufacturing site copy) must be sent to J. MORITA TOKYO MFG. CORP.

## Preventing Accidents

Most operation and maintenance problems result from insufficient attention being paid to basic safety precautions and neglecting to assess risks.

Problems and accidents can be prevented by properly assessing risks and operating the unit in accordance with our recommendations. Carefully read the warnings and precautions listed on each page as "Contraindications/Prohibitions" and "Precautions for Use (Safety and Hazard Prevention) of Electric Medical Devices"; and operate the unit with care to prevent either damaging the equipment itself or causing injury.

The degree of harm or damage that may occur if you fail to heed the precautions and use the unit improperly are categorized as follows.

List of Safety Symbols	
 <b>WARNING</b>	Improper handling may result in severe injury (death/serious injury etc.) or damage to the equipment.
 <b>CAUTION</b>	Improper handling may result in minor injury or damage to the equipment.
<b>Symbols</b>	 This symbol alerts the user to a warning/precaution.
	 This symbol alerts the user to behavior that is prohibited.
	 This symbol alerts the user to instructions and content which must be followed.
	 This symbol alerts the user to pay attention to high temperature.
	 This symbol alerts the user to a dangerous voltage.

The user (e.g., healthcare facility, clinic, hospital etc.) is responsible for the management, maintenance, and use of medical devices.

this equipment must only be used by dentists and other legally licensed professionals.

**Please do not use this equipment for purposes other than dental practice.**







## Disclaimer



- Please be aware that we cannot assume responsibility for the following (1)-(7).
  - (1) faults/injury resulting from repairs made by personnel not authorized by MORITA,
  - (2) any changes, modifications, or alterations to our products,
  - (3) faults/injury sustained by the use of products or equipment made by other manufacturers, if not supplied by MORITA,
  - (4) faults/injury due to maintenance/repairs using spare parts other than genuine parts specified by MORITA,
  - (5) faults/injury due to failure to observe the precautions and follow the methods described in these operation instructions.
  - (6) faults/injury due to ambient conditions deviating from the conditions suitable for use of this equipment, such as the power supply and installation environment described in these operation instructions.
  - (7) faults/injury due to natural disasters such as fire, earthquake, flood, lightning etc.
- Attach the MORITA-specified handpieces and/or syringes to the chair unit and do not use parts other than those specified by us. When attaching/connecting parts other than those specified by us, there is a risk that the part may disconnect and fly off during use. Be aware that we cannot assume responsibility for faults in our product, injury or health problems if they arise under such circumstances.
- The working life (number of years of use) is 10 years (by self-certification) conditional upon regular maintenance and inspection being carried out after shipment.
- The working life over which the safety and functionality of the various parts can be maintained is described in "Safety Note for Users of Dental Treatment Units (Issued by the Japan Dental Machine Manufacturers Association)" supplied with this device. Safety checks and checks on whether functionality has diminished should be conducted during the working life and maintenance should be carried out accordingly.
- Please ensure that the unit is connected to a supply of tap water.

# 1 Installation



## 1.1 Installation

 <b>WARNING</b>	
	<p>Installation of this product should be carried out by a specialist technician (by MORITA CORP. or by a company designated by us).</p> <p>The installation must be in accordance with the supplied installation control standard.</p> <ul style="list-style-type: none"> <li>● There is a danger of accidents and faults due to unforeseen circumstances.</li> </ul>
	<p>Always ensure that this product is fixed to the floor using an appropriate method (stated in the supplied installation control standard).</p> <ul style="list-style-type: none"> <li>● If not properly fixed, there is danger that the product will topple over and cause an accident or fault.</li> </ul>
	<p>Do not use a power supply other than one of the stipulated power supply frequency [Hz], voltage [V], and permissible current [A] (or power consumption).</p> <p>Always ensure that a dedicated power supply circuit is provided for each unit, avoid sharing the power supply with other appliances and avoid a common/branching power supply.</p> <ul style="list-style-type: none"> <li>● There is a danger of accidents and faults such as fire/electric shock etc.</li> </ul>
	<p>Do not locate the unit where it is likely to get wet or in a location that gets wet.</p> <ul style="list-style-type: none"> <li>● There is a danger that a short circuit or overheating may occur and cause a fault or accident such as fire/electric shock.</li> </ul>
	<p>Do not install in a location where chemicals are stored or where gas is generated.</p> <ul style="list-style-type: none"> <li>● There is a danger of accidents and faults such as fire/electric shock etc.</li> </ul>
	<p>Do not position the power cord, ground wire, or foot control cable in a location where damage may easily occur (door, passageway etc.).</p> <ul style="list-style-type: none"> <li>● There is a danger of accidents and faults such as a short circuit/electric shock etc.</li> </ul>
 <b>CAUTION</b>	
	<p>Do not install the unit in an unstable location, such as on a slope or on a site subject to vibrations or impacts.</p> <ul style="list-style-type: none"> <li>● This may cause a fault.</li> </ul>
	<p>Do not install the unit in a location where there is a possibility of adverse effects occurring due to atmospheric pressure, temperature, ventilation, sunlight, dust, salinity, sulfur/ozone in the air, etc.</p> <ul style="list-style-type: none"> <li>● This may cause a fault.</li> </ul>
	<p>Do not install this unit in the vicinity of equipment that generates electromagnetic waves such as communication equipment, elevators etc.</p> <ul style="list-style-type: none"> <li>● This may cause a malfunction.</li> </ul>
	<p>Keep heaters away from the device. Also, make sure that it is not exposed to warm air directly.</p> <ul style="list-style-type: none"> <li>● Heat softens and expands the tube, causing breakage or other damage.</li> </ul>
	<p>Do not install this unit in a location which does not meet the working environment conditions stipulated below.</p> <p>① temperature: 10-35°C</p> <p>② RH: 30-75% (without condensation)</p> <p>③ Air pressure: 700-1060 hPa</p> <ul style="list-style-type: none"> <li>● This may cause a fault.</li> </ul>

## 1.2 Preparation

 <b>WARNING</b>	
	<p>Use tap water to supply the water line of the main unit.</p> <ul style="list-style-type: none"> <li>● The use of cleansers, industrial water, unhygienic water etc. may damage the patient's health. Moreover, this may damage the pipes inside the main unit and may cause a fault.</li> </ul>

## 1.3 Connection of Instruments

 CAUTION	
	Connect the main tube of each instrument before starting use. ● An inadequate connection may cause a water or air leak. If a connector is pushed at an angle or if it is forcibly turned and bent, there is a danger of damage.
	Keep each instrument in its holder when not in use. ● An accident/fault may occur due to unforeseen circumstances during operation of the vacuum equipment/instruments.

Connect the main tube to the tray, assistant-side holder, and unit, and put the instruments in their holders. Refer to the following.

- |  |   |
|--|---|
| · For each main tube connection                                  | ☞ Supplied installation control standard                    |
| · For the syringe case/nozzle of the threeway syringe connection | ☞ pp. 58-61   |
| · For the vacuum syringe/saliva ejector                          | ☞ pp. 62-63   |
| · For various instrument connections                             | ☞ see the operation instructions supplied with each product |

## 1.4 Installation of Filters

 CAUTION	
	Before commencing use, always ensure that filters are fitted to the relevant parts.
	● Failure to install filters or improper installation may lead to a drop in performance, faults/pipe clogging, etc.

The filters are provided to protect the inner parts from contamination and foreign matter.

For how to install, refer to relevant items in "5. Caring for the Unit" of these operation instructions.

1. Vacuum filter for vacuum pipeline
2. Vacuum filter for saliva ejector
3. Basin filter
4. Drain trap filter
5. Muffler sponge
6. Sterapore cartridge (for water)
7. Sterapore cartridge (for air) **Option**

# 2 Part Names

## 2.1 Chair Type

### ■ Contour type

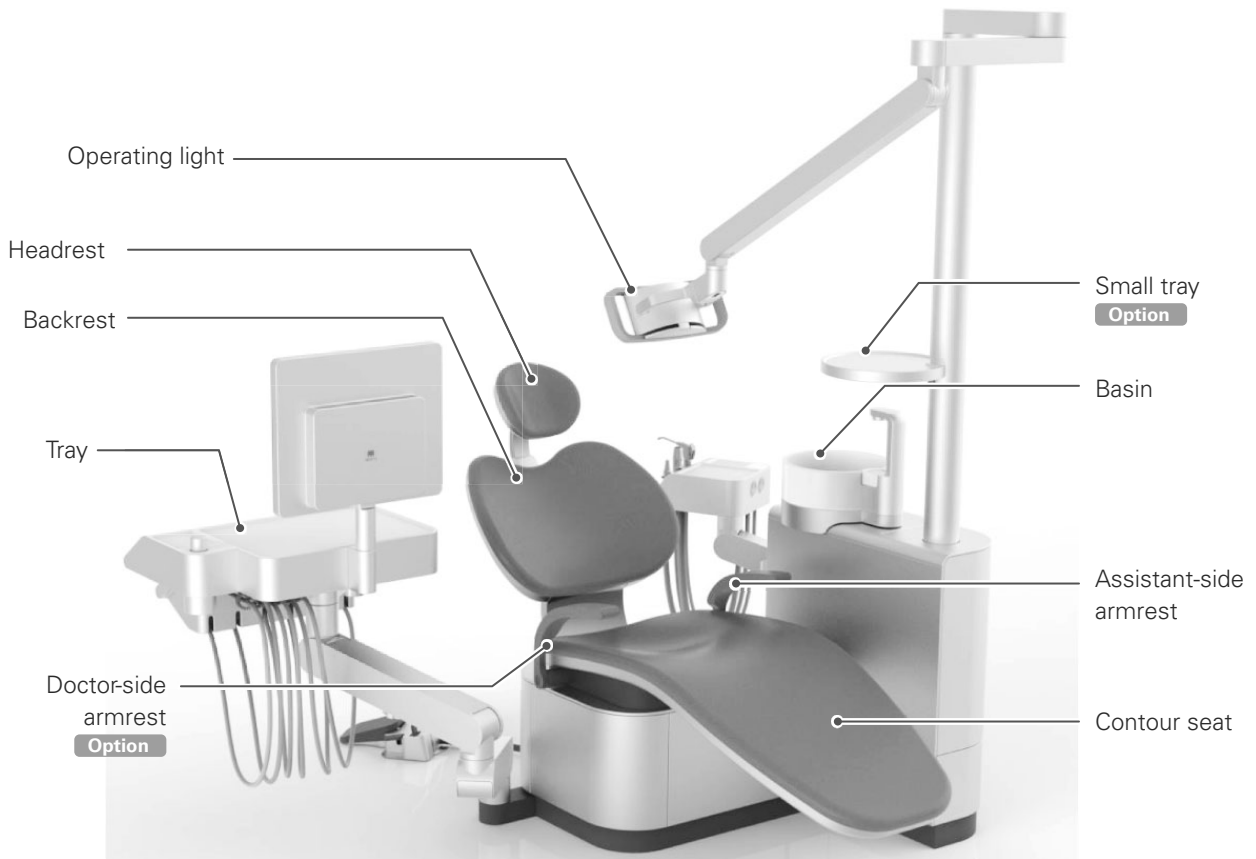

### Stand unit

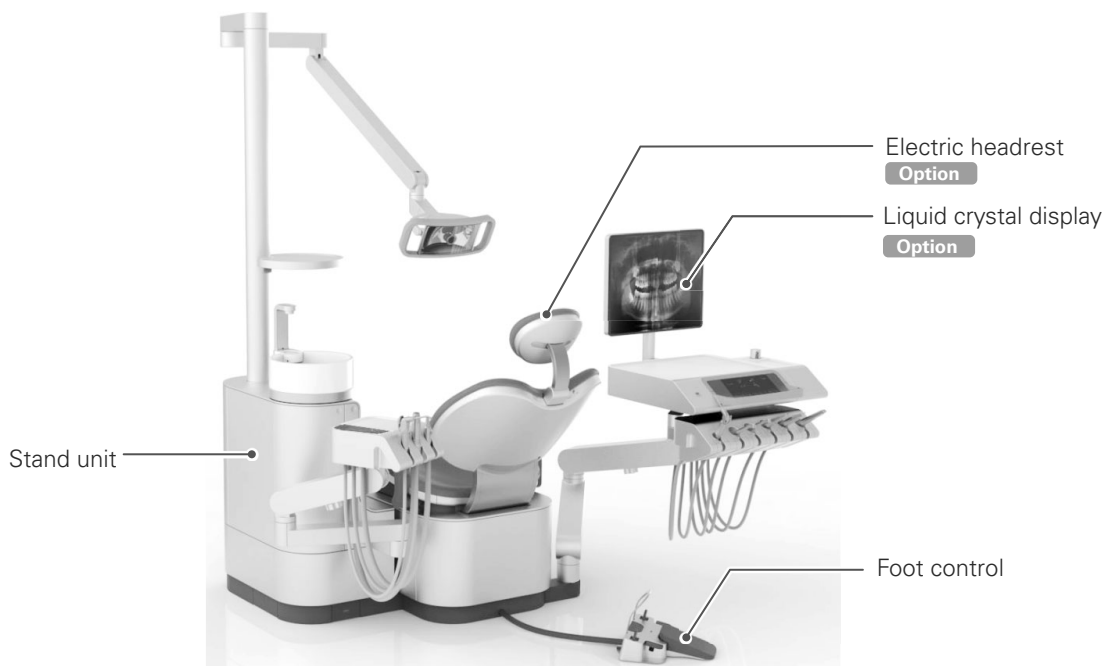

■ **Foot support type**

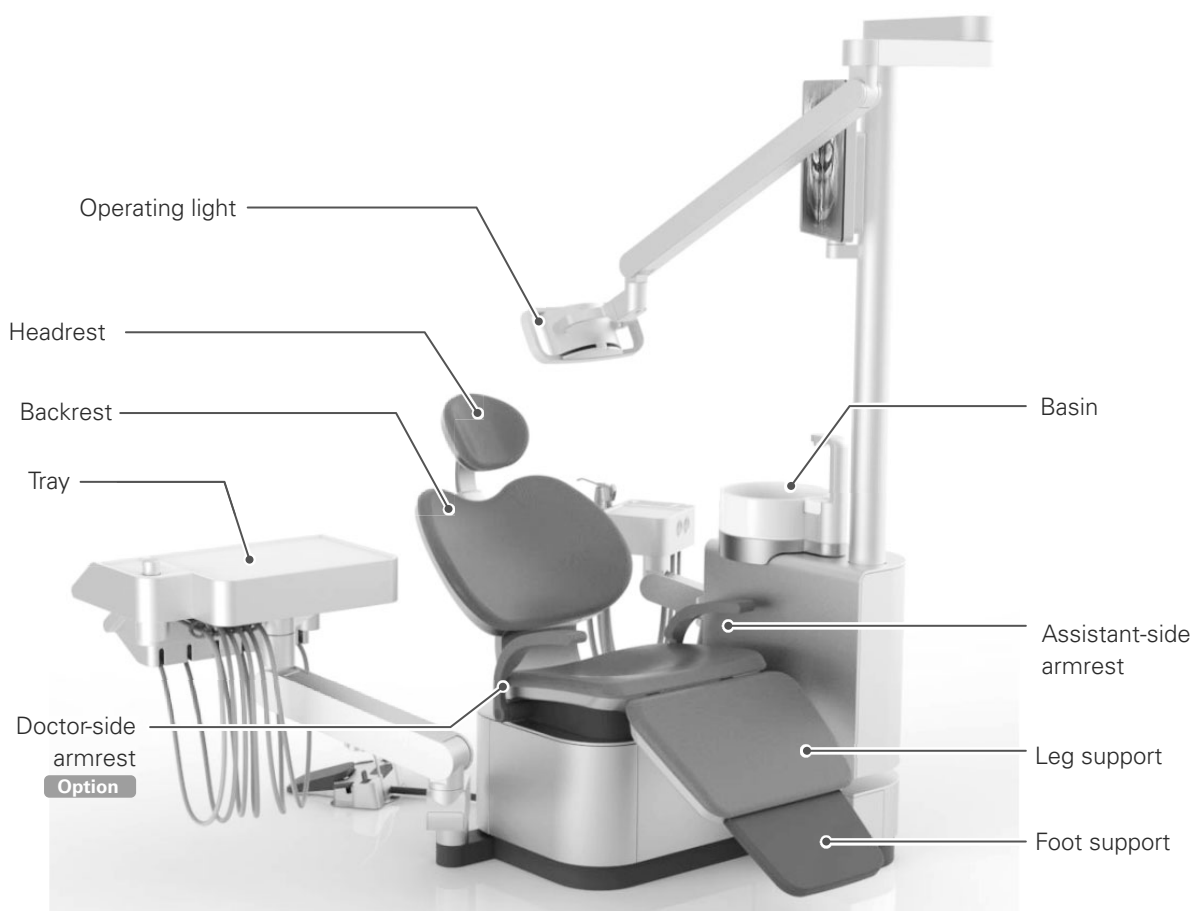

**Chair mount unit**



## 2.2 Tray Type

### ■ Floor-mounted tray type



### ■ Over-the-patient tray type



■ Cart



## 2.3 Foot control

### ■ Part Names

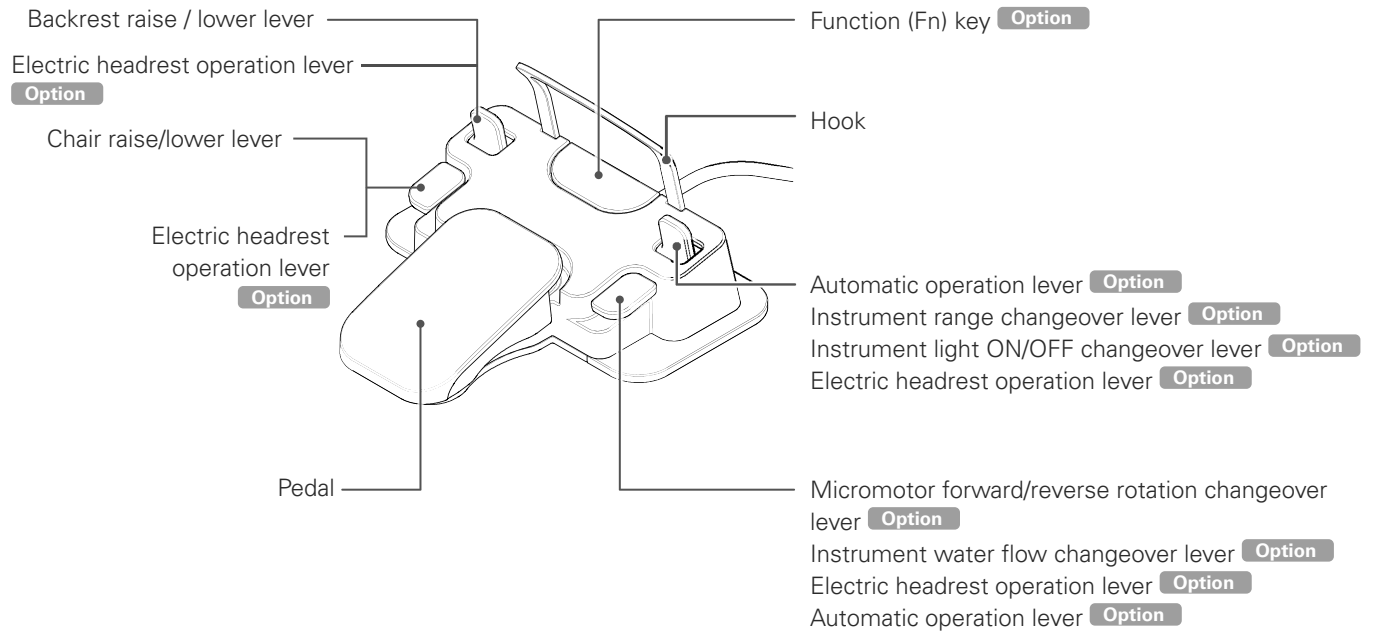



## 2.4 Accessories

Tray paper	1 set	Mazak P	1 bottle
Paper cup	1 set	Protection sheet	3 sheet
Top for paper cup	1 set	Operation instructions	1 copy
Headrest cover	1	Installation instructions	1 copy
Spare fuse	1 set	Warranty Card	1 copy
Dedicated cleaner for cleaning	1 bottle	Safety notes	1 copy
Air nozzle (for removing spray solution)	1		

Other accessories for each instrument are included.

# 3 Actions Before and After Use

Refer to the various operation instructions for details of handling the air turbine handpiece, micromotor handpiece, operating light, etc. (separate volumes).

Use this unit in the following environment.

Temperature: 10-35°C, humidity: 30-75%RH (without condensation), air pressure: 700-1,060 hPa

※ When using equipment that has not been used for a while, always be sure to check that the equipment operates normally and safely prior to use.

## 3.1 Preparation Before Use

### 3.1.1 Water/Air Supply and Main Switch

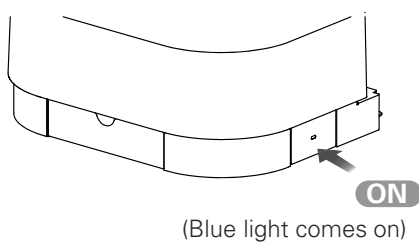
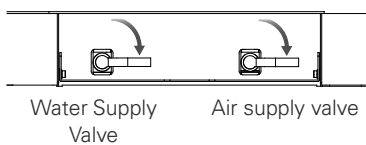
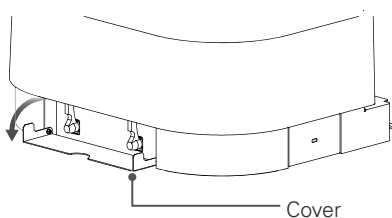

#### 1 Open the water supply/air supply valves

- ①. Open the cover.
- ②. Lower the water supply valve/air supply valve lever in the direction of the arrow and open the water supply/air circuits in the chair.

#### 2 Turn the power ON

<b>⚠ CAUTION</b>	
	When power is ON, do not subject the main unit to impacts or vibration. <ul style="list-style-type: none"><li>● Accidents and faults due to unforeseen circumstances may occur.</li></ul>
	When switching the power ON, check that the switches for operation of the device such as Up/Down, Upright/Reclining positions of the chair are not ON. <ul style="list-style-type: none"><li>● The device may suddenly start to move and there is the risk of injury.</li></ul>

Press the main switch of the chair. The power comes ON.

The power goes OFF automatically if the chair has not been operated for a certain period of time.

(= automatic power OFF function: initial setting is 120 minutes)

Automatic power OFF function

☞ p. 94

## 3.2 Interruption/Completion of Use

<b>⚠ WARNING</b>	
<b>!</b>	Always turn the main switch OFF and close the water supply valve when treatment has been completed, when the device is not used for a long time, or when there is a malfunction/abnormality.
	<ul style="list-style-type: none"> <li>● Accidents and faults/problems such as fire due to a short circuit and water leakage may occur.</li> </ul>
<b>⊘</b>	Ensure that all wiring, tubes etc. are connected when supplying power and water/air to the main unit.
	<ul style="list-style-type: none"> <li>● Failure to do so may result in accidents and faults due to a short circuit, heat generation, water leaks etc.</li> </ul>
	<p>Do not expose the power supply to water or leave dust adhering to it.</p> <p>A water leak occurs, turn the main switch OFF, stop using the device, wipe away moisture and dry thoroughly before resuming use.</p> <p>If there is adhering dust, turn the main switch OFF and wipe off the dust with a dry cloth etc.</p> <ul style="list-style-type: none"> <li>● If use of the unit is continued while there is an abnormality, accidents such as fire and electric shock due to a short circuit, and faults such as heat generation etc. may occur.</li> </ul>

### ■ When use is interrupted, after completion of treatment

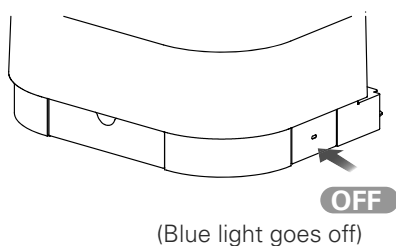

#### 1 Turn the power OFF

Press the main switch of the chair.  
The power goes OFF.

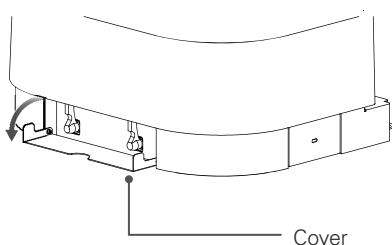

#### 2 Closing the Water Supply/Air Supply Valves

①. Open the cover.

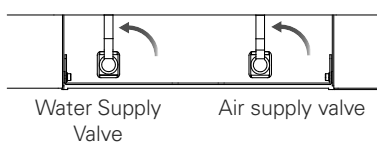

② Raise the water supply valve/air supply valve lever in the direction of the arrow to close the water supply/air supply line to the chair.

③ Close the cover.

## ■ In Event of a Fault or Abnormality

If a fault or an abnormality occurs, be sure to turn the main switch OFF and shut off the water and air supplies.

- when the water supply does not stop such as with the failure of an automatic filler
- when replacing the sterapore cartridge
- when a localized water leak is detected
- when there is a failure/repair request
- when there is a disaster such as an earthquake

## 3.3 Storage

Observe the following storage/transportation conditions when storing/transporting the main unit.

- ① Temperature : -10-70°C
  - ② Humidity : 10-85% RH (without condensation)
  - ③ Air pressure : 700-1,060 hPa
  - ④ Do not install the unit in an unstable location, such as on a slope or on a site subject to vibrations or impacts.
  - ⑤ Do not install this unit at a site where there is a possibility of adverse effects occurring due to atmospheric pressure, temperature, ventilation, sunlight, dust, salinity, sulfur/ozone in the air etc.
- Failure to follow these instructions may cause a fault.

# 4 Method of Operation

## ⚠ WARNING

⊘	<p>Do not place objects or bring fingers, feet, or footwear near to movable parts such as the seat and backrest hinge of the main unit. (refer to the List of Precautions)</p> <ul style="list-style-type: none"> <li>● There is a risk that items will be caught during operation and accidents such as injury and damage/faults may occur.</li> </ul>
	<p>Do not place heavy objects on the edges of the seat/backrest/headrest or on the light/tray etc. and do not apply excessive forces to these areas.</p> <p>Avoid behavior such as standing/jumping on the main unit.</p> <ul style="list-style-type: none"> <li>● There is a danger of the main unit toppling over or incurring damage which results in an accident or fault.</li> </ul>
	<p>Do not spill liquid inside the main unit and do not introduced easily combustible items or metals.</p> <ul style="list-style-type: none"> <li>● If the unit continues to be used as is, there is a danger of accidents and faults such as fire/electric shock etc.</li> </ul>
	<p>Do not place a heat source such as a heater near the main unit.</p> <ul style="list-style-type: none"> <li>● There is a risk of deformation and damage to the main unit and rupture of the piping due to residual air pressure.</li> </ul>
!	<p>Observe the following points during operation of the main unit and refer to the "List of Precautions" in the next section to ensure safety.</p> <ol style="list-style-type: none"> <li>① Apart from the doctor and assistant, no-one should operate the main unit without permission (as a mischievous prank etc.)</li> <li>② Keep an eye on patients (especially infants and the elderly)</li> <li>③ Do not allow patients to adopt a dangerous posture (put their legs on either side of the seat, stand on the seat, kneel on the seat, sit while wearing footwear such as heels and slippers etc.)</li> <li>④ Do not allow chair movement/positioning to make the patient uncomfortable (sudden headrest movement for patient with a neck problem or supine posture for patient with lower pain, etc.)</li> <li>⑤ Do not allow hands, parts of the body/belongings etc. to come close to the movable parts of the main unit and vicinity (patient grasping the tray arm, placing hands at the base of the backrest, sitting with a phone in their pocket, etc.)</li> <li>⑥ Do not allow more than one patient on the seat (holding a child etc.)</li> <li>⑦ Do not let anyone unrelated to treatment enter the surrounding area (child approaching/touching the unit, etc.)</li> <li>⑧ Do not move the small tray etc. close to the surrounding walls/windows/equipment/appliances etc. (collision etc. may occur during operation)</li> <li>⑨ Do not behave in a way that could be considered dangerous</li> <li>⑩ Do not operate the chair in a situation that could be considered dangerous</li> </ol> <ul style="list-style-type: none"> <li>● There is a danger of accidents causing injury etc., damage/faults occurring.</li> </ul>
	<p>If there is a risk of injury or a collision during automatic operation of the main unit, carry out the following stop procedures immediately.</p> <p>(A) Step on the foot pedal</p> <p>(B) Operate the manual operation lever (either up, down, upright, or reclined)</p> <p>(C) Turn the main switch OFF</p> <ul style="list-style-type: none"> <li>● There is a danger of accidents causing injury etc., damage/faults occurring.</li> </ul>

## ⚠ CAUTION

⊘	<p>If a patient uses a pacemaker, do not simultaneously use the ultrasonic scaler, electrocautery scalpel and root canal length measuring instrument.</p> <ul style="list-style-type: none"> <li>● The pacemaker may malfunction and damage the patient's health.</li> </ul>
	<p>Always be sure to turn the main switch OFF when using an electrocautery scalpel near and around the main unit. Refrain from using devices generating electromagnetic waves such as cell phones etc.</p> <ul style="list-style-type: none"> <li>● Malfunctions arise due to electromagnetic waves and an accident/fault may occur due to unforeseen circumstances.</li> </ul>

## 4.1 Precautions When Operating the Chair

Always carry out a safety check before operating the chair (automatic/manual). In particular, take care to avoid touching or pinching the patient and surrounding instruments etc. by following the precautions shown in the figure below.

### 4.1.1 Precautions When Operating the Chair

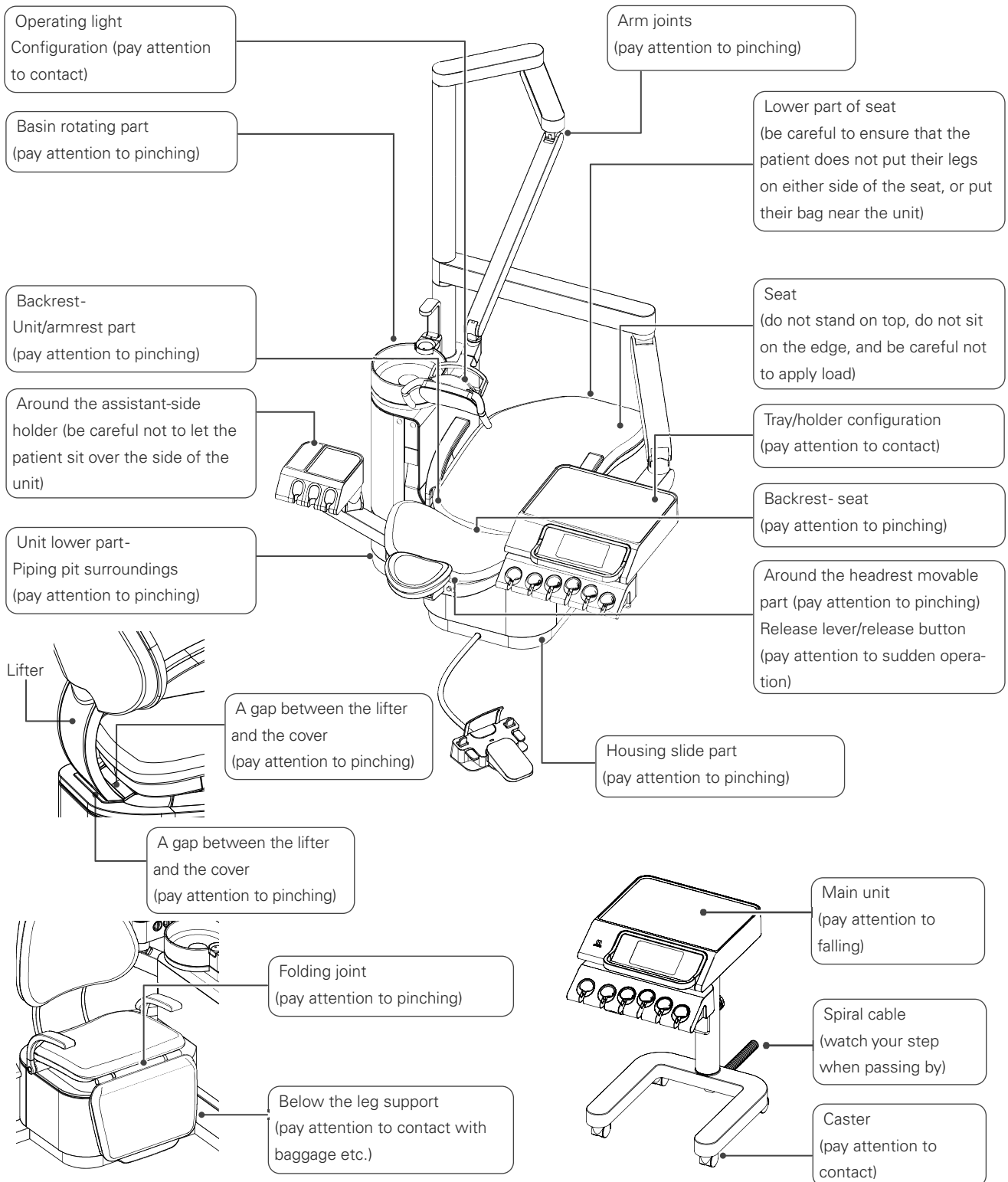

## 4.1.2 Safety Switch

### ■ Automatic Shutdown Using the Safety Switch

If any of the following situations arise during automatic operation, the safety switch is activated and the system stops automatically.

The display shows that the system has automatically stopped or the safety lock is on.

Check the relevant part, remove the obstruction then resume use.

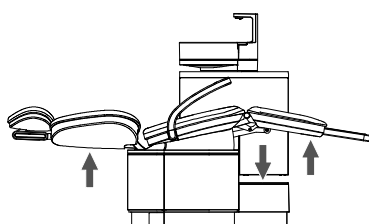

① While descending, the backrest is pushed from below. Or, the piping pit is pushed from above. And also the undersurface of the leg support is pushed upwards.

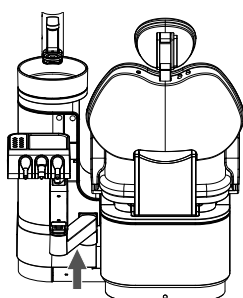

② While the chair is going down, the assistant-side arm rises up.(Chair mount unit)



③ When the chair is going up, the assistant-side arm rises up.(Stand unit)



④ While uprighting, the assistant-side arm rises up.

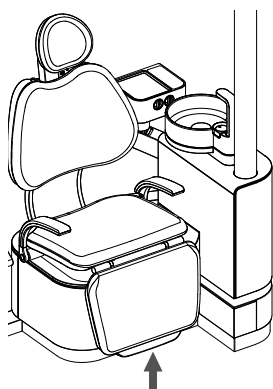

⑤ While the chair is going down, the edge of the foot support is pushed.

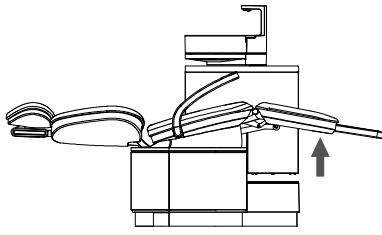

⑥ While raising the backrest, the back side of the foot support is pushed upward.

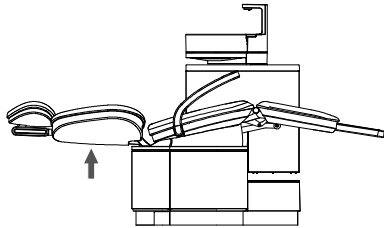

⑦ While reclining, the backrest rises up.

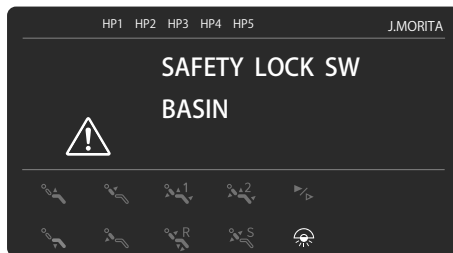
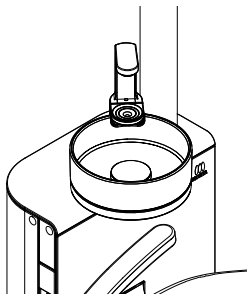

⑥ While the chair and the backrest is going up, the basin moves towards the patient.  
Or, an operation to raise the chair or raise the backrest is performed when the basin is at the patient's side.  
When the chair is going down, the basin moves towards the patient.  
Or, an operation is performed to lower the chair when the basin is at the patient's side. (stand unit type only)

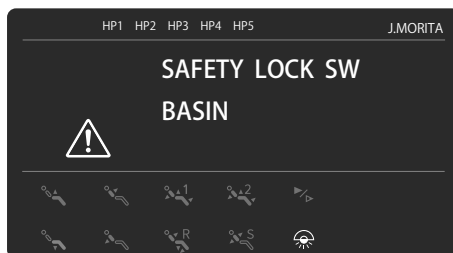
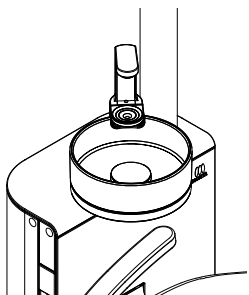

⑦ When the chair is going up, the basin moves towards the patient.  
Or, an operation is performed to raise the chair when the basin is at the patient's side. (stand unit type only)



## 4.2 Operation Panel

### 4.2.1 Display Panel

#### ⚠ WARNING



Always be sure that rotation/vibration has stopped when changing over and adjusting instruments.

- Accidents and faults due to unforeseen circumstances may occur.

Perform operations using the display panel. Press the icons to perform operations.

#### ■ Home screen

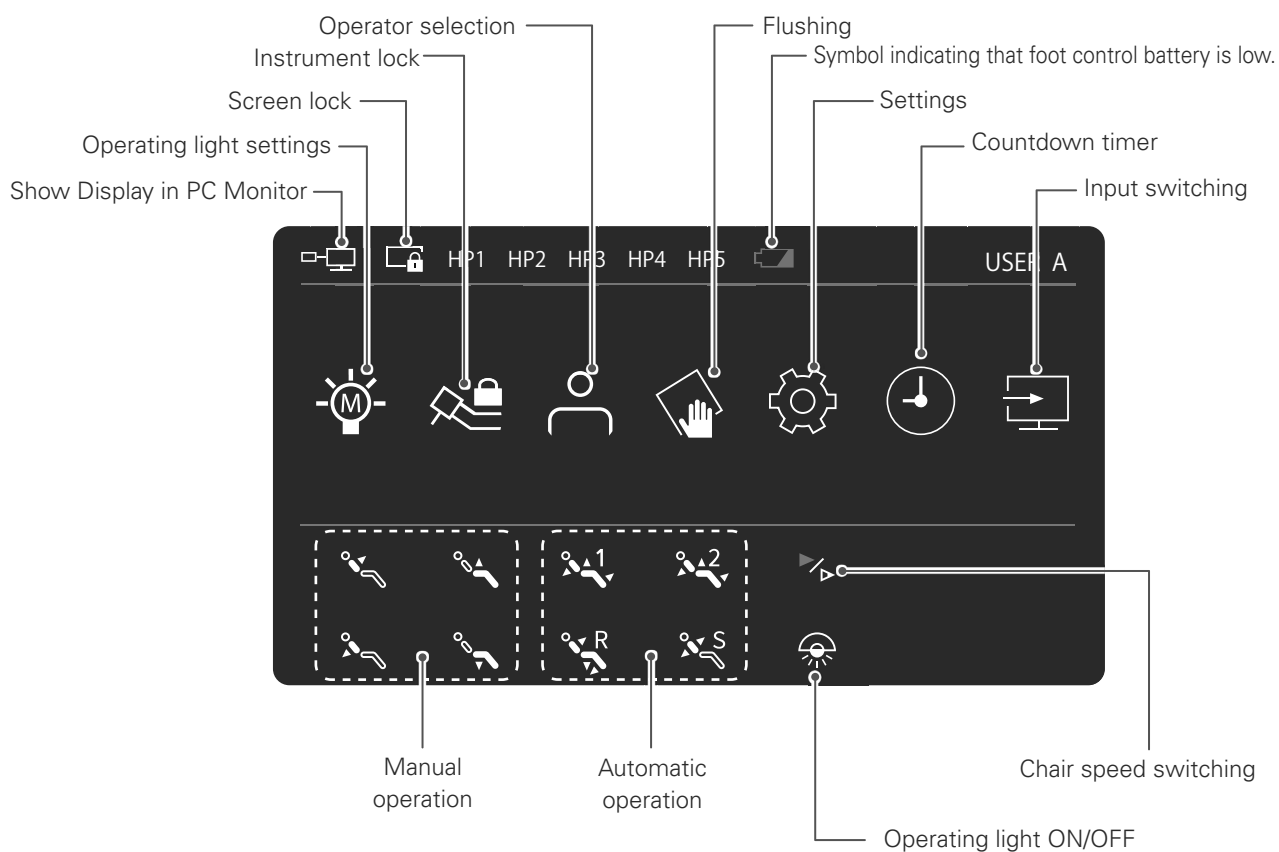

#### Operator selection

Switches operators.

You can register up to 5 settings patterns, including instrument settings and individual user settings.

☞ p. 87



#### Operating light settings

Set range and brightness level of operating light.

☞ p. 81 p. 89



**Instrument lock**

Temporarily lock the handpiece circuits not in use so that they cannot be operated.

☞ p. 88



**Countdown timer**

This is a digital countdown timer. You can set up to 6 patterns.

☞ pp. 83-86



**Flushing**

Flush the vacuum system.

☞ pp. 121-123



**User settings**

Configure settings common to all operators or configure settings for each operator individually.

☞ pp. 90-109



**Chair speed switching**

Changes chair operation speed.

The change takes effect for both manual operation and automatic operation.

☞ p. 92



**Operating light ON/OFF**

Switch the operating light ON/OFF.

☞ p. 80



**Screen lock**

Lock the system so that the screen icons do not function.

Long press the screen lock icon until you hear a "beep" sound. The screen is now locked. Long press again to unlock.

Note that you can still use the foot control while the screen is locked.



**Symbol indicating that foot control battery is low**

This lights up when the battery of the cordless foot control **Option** has run down.

For how to replace the battery, refer to "4.4.3 Cordless Foot Control".

☞ p. 31



**Show Display in PC Monitor**

The screen of the system display panel can be displayed on the liquid crystal display.

☞ p. 90



**Liquid crystal display input switching**

Switches the input of the liquid crystal display.

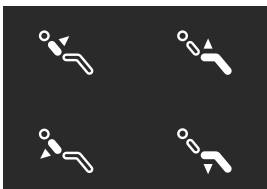

**Manual operation of chair**

Use to switch the operations for moving the seat up and down and controlling the backrest to manual.

☞ p. 26



**Automatic operation of chair**

Use to switch the operations for moving the seat up and down and controlling backrest to automatic.

☞ p. 27

## 4.2.2 Assistant-side Operation Panel

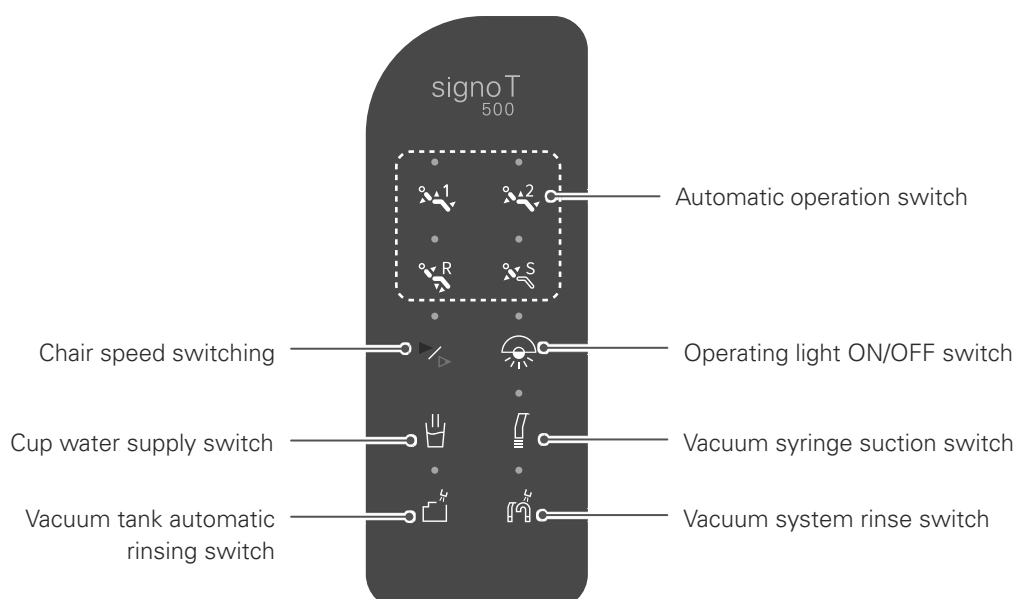

### Chair speed switching

Changes chair operation speed.  
The change takes effect for both manual operation and automatic operation.

☞ p. 93



### Operating light ON/OFF

Switch the operating light ON/OFF.

☞ p. 80



### Cup water supply

Manual supply of cup water.  
Water is supplied while the switch is pressed.

☞ p. 79



### Vacuum syringe suction

Switch the vacuum syringe suction ON/OFF.

☞ p. 62



### Vacuum tank automatic rinsing

Automatically rinses the vacuum tank.  
Press the switch to automatically rinse the inside of the vacuum tank.

☞ p. 127



### Vacuum system rinsing

Rinse out the vacuum piping and saliva ejector piping.

Position the vacuum syringe and the saliva ejector in the unit and press the switch to start rinsing.

☞ pp. 125-126



### Automatic operation of chair

Use to switch the operations for moving the seat up and down and controlling backrest to automatic.

The operation is the same as the auto operation on the display panel.

☞ p. 27

## 4.3 Chair

### 4.3.1 Manual Chair Operation

#### ■ Raising and lowering the chair

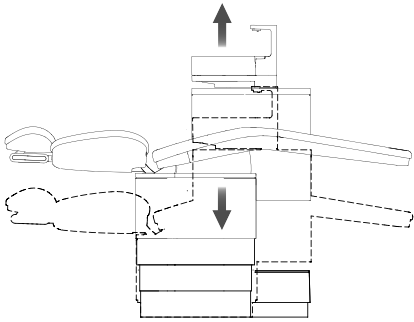

Raise and lower the chair using the manual operation icons on the display panel or the foot control.

The chair will operate for the period you continue to press the icon or operate the foot control.

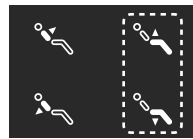

Display panel

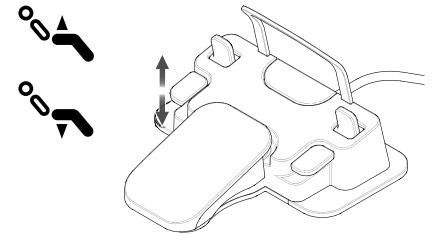

#### ■ Moving the backrest upright

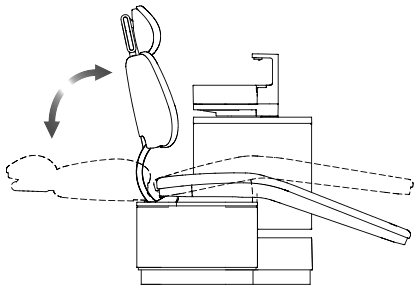

Control the backrest position using the display panel or foot control. The chair will operate for the period you continue to press the icon or operate the foot control.

During this operation, the backrest temporarily stops at the backrest reset position. To make it more upright, release the lever and then operate it again.

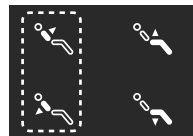

Display panel

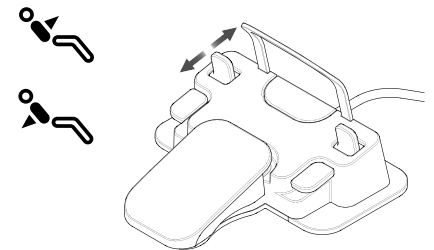

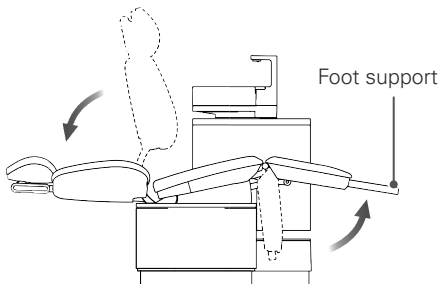

#### Foot support specifications



When the backrest is flattened, the foot support comes out to support the patient's feet.

None of the above chair operations will work while the air turbine handpiece or micromotor is running or while the ultrasonic scaler is in operation.

### 4.3.2 Automatic Movement of Chair

 <b>WARNING</b>	
	Do not leave the chair when it is operating and make sure that the patient is in the correct position. <ul style="list-style-type: none"> <li>● There is the risk of accident such as injury.</li> </ul>
	Do not push any icon or switch with a sharp object such as a dental instrument as this could damage the switch surface. <ul style="list-style-type: none"> <li>● This may cause a malfunction or fault.</li> </ul>

Use to move the seat up and down and control the backrest automatically.  
Press the relevant icon once to automatically move the seat and backrest to the corresponding stop position.

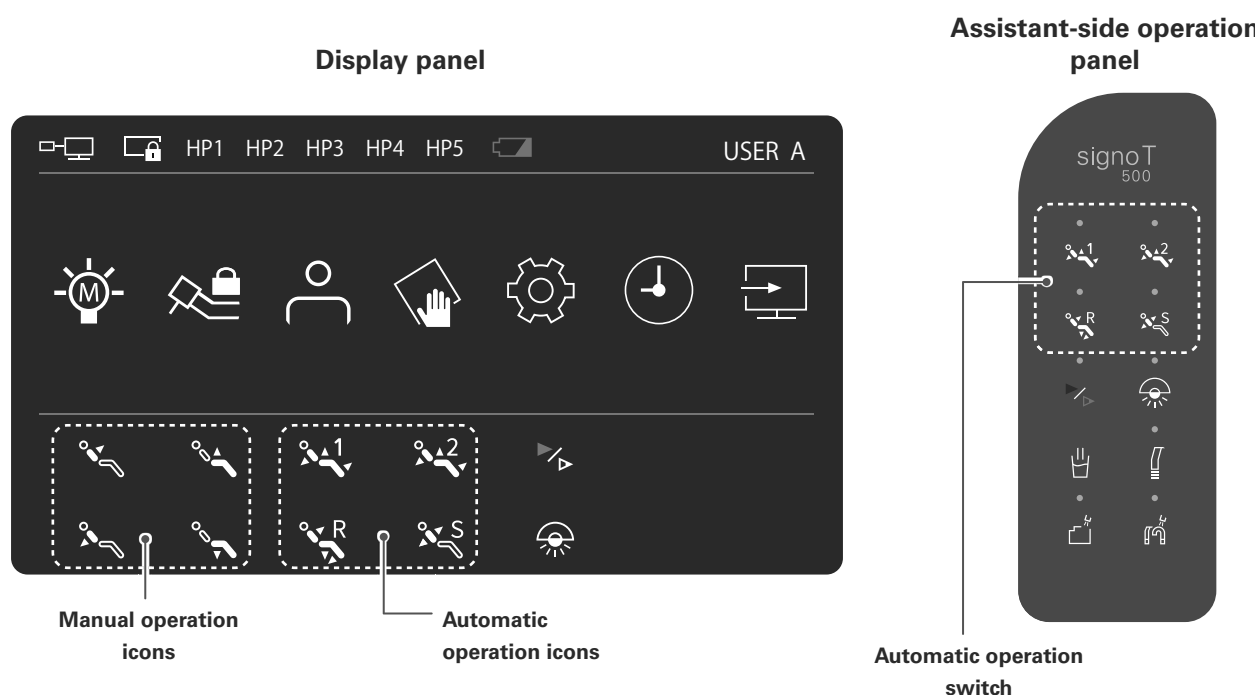

#### ■ AUTO1/AUTO2



Chair raise/  
lower lever      Backrest raise/  
lower lever

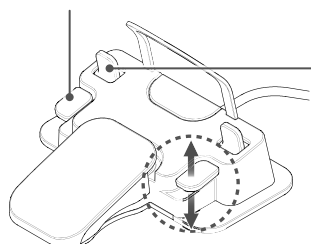

#### Display panel operation

Mainly used at the start of treatment.  
Use it to move the chair to set treatment positions.

(Setting the treatment position)

- ① Move the chair to the desired position using the manual operation icons on the display panel, or the chair raise/lower lever and backrest raise/lower lever on the foot control.
- ② Press and hold the desired icon (AUTO1 or AUTO2) for about 5 seconds. Setting is completed if the “beep” alarm sounds.

#### Foot control operations (extended function) Option

Operate the lever on the foot control.  
(hold the lever for 1 second or more to prevent malfunction)

- Up position      : AUTO1  
Down position    : AUTO2

## Reset



### Display panel operation

Mainly used at the completion of treatment.  
Use to move the seat and backrest to the set position.  
(Factory settings- seat: 450 mm, backrest: 70°)

(Setting the treatment position)

- ① Move the chair to the desired position using the manual operation icons on the display panel, or the chair raise/lower lever and backrest raise/lower lever on the foot control.
- ② Press and hold the reset icon for about 5 seconds. Setting is completed when the “beep” alarm sounds.

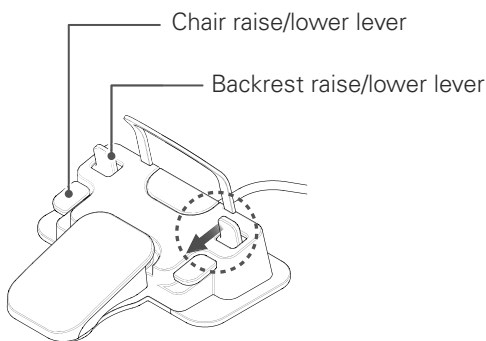

### Foot control operations (extended function) Option

Operate the foot control lever in the direction of the arrow.  
(hold the lever for 1 second or more to prevent malfunction)

## Soft Memory



### Display panel operation

Mainly used to allow gargling and to return to the original treatment position.  
Press once to move the gargling position. The chair moves to the lowest position and the backrest moves to the most upright position (about 70°) (factory setting). Press again to return to the previous treatment position.

Note that the gargling position applies only to the vertical position of the chair.

(Setting the chair vertical position)

- ① Move to the desired position using the manual operation icons on the display panel, or the chair raise/lower lever and backrest raise/lower lever on the foot control.
- ② Press and hold the soft memory switch for about 5 seconds. When you hear a “beep” sound, the setting is complete.

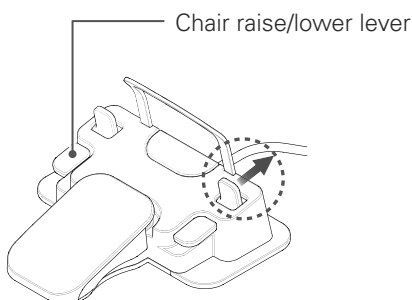

### Foot control operation Option

Operate the foot control lever in the direction of the arrow.  
(hold the lever for 1 second or more to prevent malfunction)

## ■ Interrupting Automatic Operation

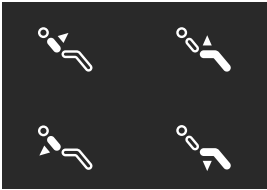

### Manual interruption of automatic operation

To interrupt automatic operation, perform one of the following operations.

- Press any automatic operation icon
- Press any icon for manual operation
- Step on the foot control pedal
- Operate a manual operation lever on the foot control
- Turn the main switch OFF

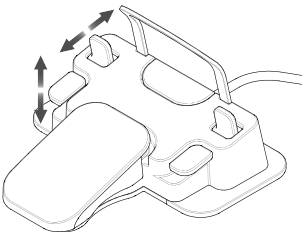
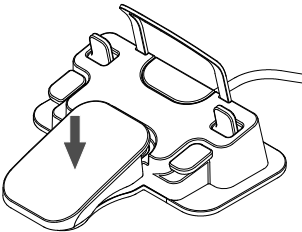

## Chair speed switching

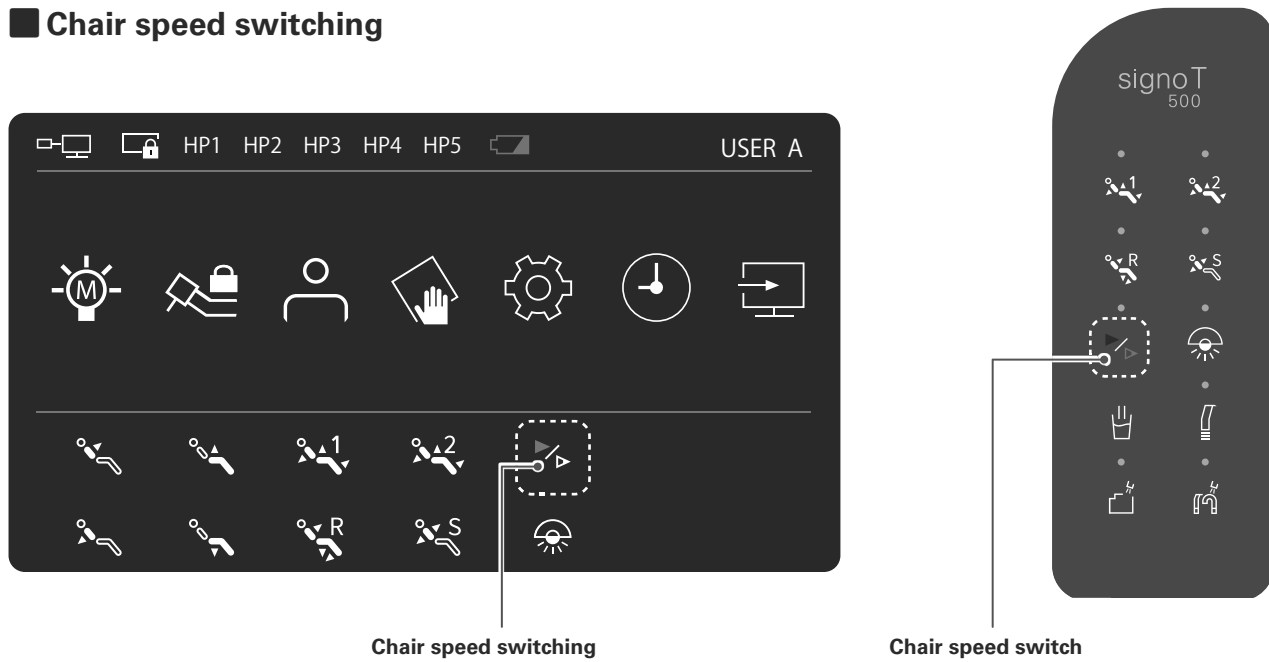

Changes the speed at which the chair moves up and down and the backrest raises and lowers. Press the chair speed switching icon on the display panel or the chair speed switch on the assistant-side operation panel to toggle between speeds.

Note that the speed change takes effect for both manual operation and automatic operation.

Orange: low speed

Blue: high speed

## Chair Lock Switch

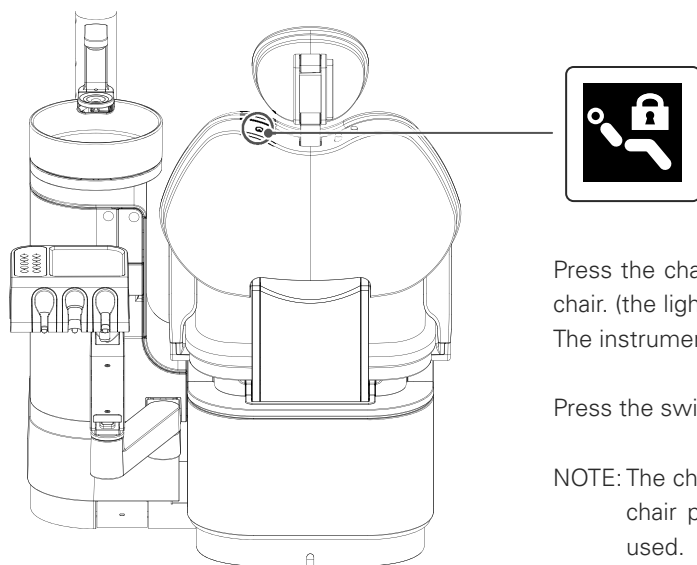

Press the chair lock switch when you want to disable the functions of the chair. (the light on the switch remains lit while the chair is locked)  
The instruments can still be used.

Press the switch again to unlock.

NOTE: The chair will not operate when the switches of the foot control, the chair position automatic switches, or the raise/lower switches are used.



### 4.3.3 Cordless Foot Control Option

#### ⚠ WARNING

⊘	Behavior may become unstable due to communication trouble. If abnormality occurs, please discontinue use. ● There is the risk of an accident due to a malfunction.
!	Always be sure to turn OFF the main switch of the chair unit and the power switch of the cordless foot control when replacing the batteries. ● The chair may move suddenly and cause an accident.

### ■ Method of Operation

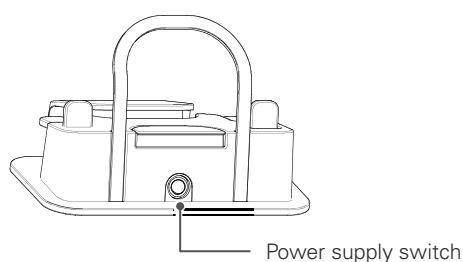

- ① Turn the power switch ON.  
Operate the pedal and operate the chair.
- ② After the day's treatment, turn the power switch OFF.

### ■ Battery Replacement

The cordless foot control is powered by batteries.

Replace the batteries roughly every year.

Always be sure to turn OFF the main switch of the chair unit before replacing the batteries.

When replacing the batteries, please observe the disposal regulations in the applicable area.

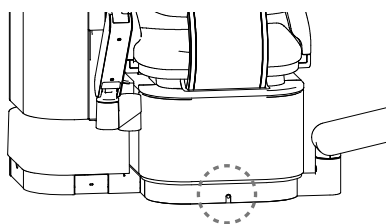

- If the batteries are low, the light at the base of the chair blinks.  
(the light is usually off)  
The low battery symbol also appears on display panel on the tray.

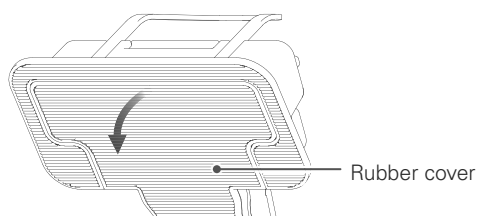

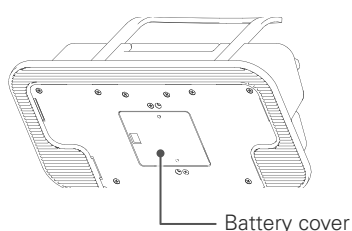

- ① Turn back the rubber cover on the lower surface.



- ② Remove the cover of the battery compartment and replace the batteries with new ones.
  - Use 3 alkaline AA batteries
 Do not use zinc-carbon batteries or rechargeable batteries. The low battery symbol may appear early.
- ③ After replacing the batteries, replace the battery cover and rubber cover as before.

### 4.3.4 Headrest Height and Angle Adjustment

<b>⚠ WARNING</b>	
	Do not put your fingers, hair, clothing etc. close to moving parts such as the headrest movable parts/slide bar. ● Accidents due to pinching and jamming etc. may occur.
	Do not adjust the angle of the headrest while a patient is seated. ● There is a risk of injury to the patient's neck/head due to sudden operation and the risk of damage/faults to the shaft part due to loads.
	Any angle adjustment of the headrest should be carried out by the doctor. Do not allow an assistant or a patient to touch the release button or the release lever when the headrest is in an unsupported position. ● This could result in a sudden drop or movement of the headrest, resulting in injury or causing an accident, damage or fault.
	When adjusting the angle of the headrest or shortening the slide bar, always move the headrest slowly while supporting it with your other hand. Check that it is securely fixed after adjustment. ● The headrest may drop suddenly and accidents such as injury and damage/faults may occur. There is the risk that sudden movement may hurt the patient's neck/head.

#### ■ Twin-axis headrest

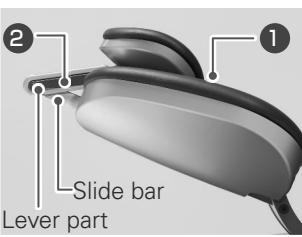
<b>⚠ WARNING</b>	
	When adjusting the angle of the headrest and when setting it to the following position, push the headrest against the backrest (1) or tilt the lever part to the slide bar side (2). ● For adjustment position shown in the following figure, when a load is applied while the head part (or lever) is not fixed it may damage the headrest, lever part and slide bar and cause accidents such as an injury.
	

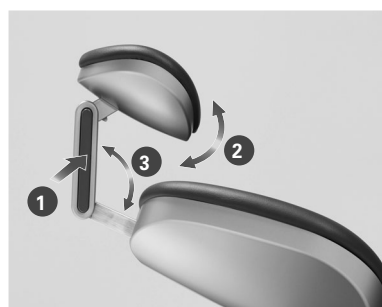

#### Angle adjustment

When the release lever (1) is pressed, the head portion (2) and neck portion (3) each move.  
The angles are fixed at the position where the release lever is released.

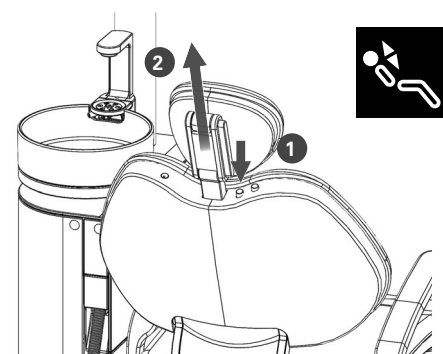

#### Height Adjustment

Have the patient take their head off the headrest.  
While pressing the slide bar release button (1), hold the headrest and adjust the height (2). When the slide bar release button is released, the slide bar is fixed.

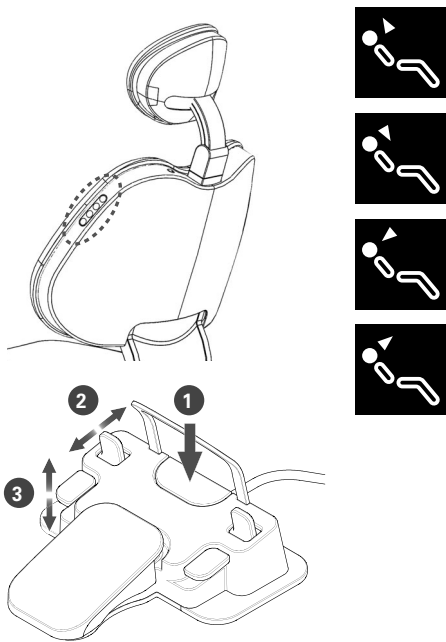

**Angle/height adjustment**

Adjust the height and angle of the headrest using the operation switches on the side of the backrest. Press and hold down the switches to make adjustments. **Option**

When the foot control function (Fn) switch (1) is pressed, height (3) and angle adjustment (2) are carried out with the foot control operation levers.

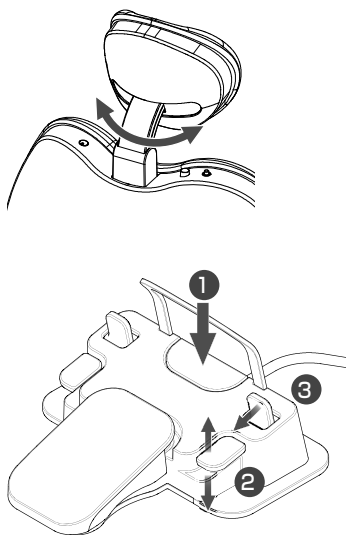

**Rolling Operation** **Option**

When the foot control function (Fn) switch (1) is pressed, rolling operation (2) and resetting operation (3) is carried out with the foot control operation lever only while it is ringing.

When the reset operation is performed, the headrest returns to the center position.

The alarm sounds for about 3 seconds. Please start operation during that time. If no operation is performed, it returns to the original state.

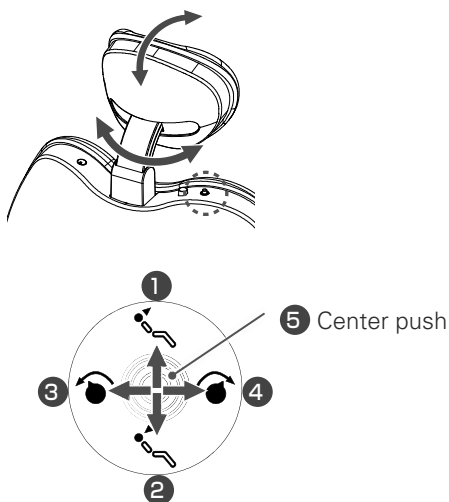

**Rolling Operation (Operating stick for rolling)** **Option**

Rolling operation of the backrest part When you knock down the operation stick, you can make the headrest stand up, tilt, turn left and right.

- Standing: 1
- Tilting : 2
- Left rotation: 3
- Right rotations: 4
- Rolling reset: 5

## Natural Movement Headrest Option

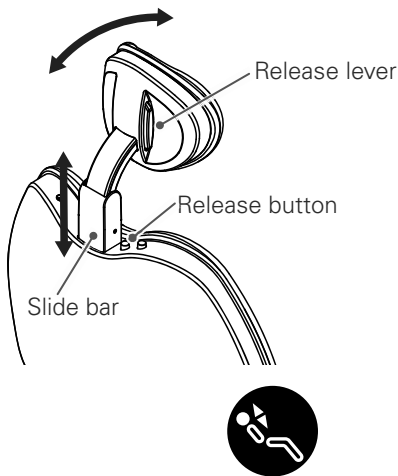

### Angle adjustment

When the release lever is pressed, the headrest move. The angles are fixed at the position where the release lever is released.

### Height Adjustment

Have the patient take their head off the headrest. While pressing the slide bar release button, hold the headrest and adjust the height. When the slide bar release button is released, the slide bar is fixed.

## 4.3.5 Backrest Height Adjustment

### Backrest Slide Mechanism Option

<b>⚠ WARNING</b>	
	Do not put your fingers, hair, clothing etc. close to moving parts. <ul style="list-style-type: none"> <li>● Accidents due to pinching and jamming etc. may occur.</li> </ul>
<b>⚠ CAUTION</b>	
	Always ensure that backrest height adjustment is carried out by the doctor. Do not allow an assistant or a patient to touch the release button when the headrest is in an unsupported position. <ul style="list-style-type: none"> <li>● Failure to do so will cause the backrest to move abruptly and accidents such as injury and faults may occur.</li> </ul> Adjust the height of the backrest to the reset state (with the backrest upright) and do not apply a load to the seat surface. Check that it is securely fixed after adjustment. <ul style="list-style-type: none"> <li>● If the patient is left reclining, the leather part may come off and damage/faults may occur. If treatment is started without checking the seat fixing, an accident may occur.</li> </ul>

### Height Adjustment

While pressing the release button, the backrest can be slid and the height adjusted.

To extend the backrest, lift **(1)** the backrest to the desired height while holding the release button **(2)**. When the release button is released, the position is fixed.

To shorten the backrest, push the backrest down from above while pressing the release button. When the release button is released, the position is fixed.

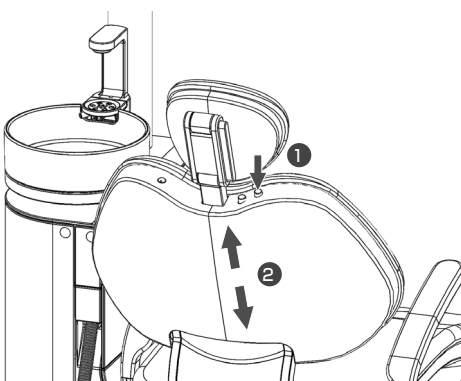

## 4.3.6 Armrest

### ■ Assistant-side armrest

This is a fixed armrest for the patient.

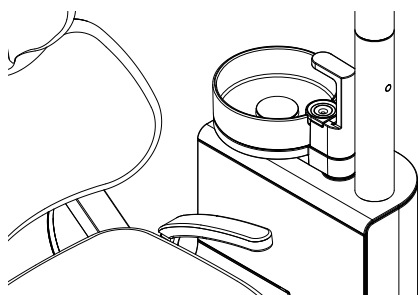

### ■ Doctor-side armrest Option

This is a movable armrest for the patient.

#### ⚠ WARNING



Do not bring your fingers close to the pivot of the doctor-side armrest. Do not bring the doctor-side holder or any other item which the armrest might hit into the vicinity of the armrest.

- Accidents such as injuries due to pinching may occur.

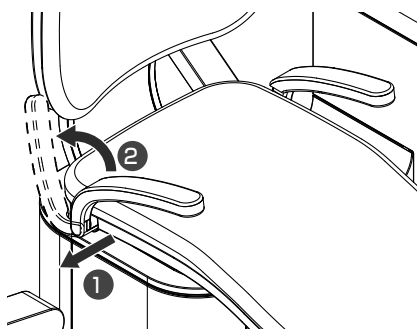

It can be raised up so as not to hinder the entry and exit of the patient.

When it is lowered, it is locked and cannot be moved.

To raise or lower, pull the base of the armrest outward (1), then lift up (2).

To lower, lower the armrest to the position where it stops.

It will lock again at the lowest position.

## 4.4 Tray

<b>⚠ WARNING</b>	
<b>!</b>	Do not apply a load of 30 N (3 kgf) or more to the doctor-side tray.
	Do not subject the tray to excessive loads or impacts.
	● If the load exceeds 30 N, the tray may drop and an accident or damage/fault may occur.
	Always adjust the doctor-side tray knob to the appropriate state.
	In particular, in the case of the cart-type tray, always be sure to fully tighten the fixing knob
	● The tray may drop and cause an accident or damage/fault.

### 4.4.1 Tray

#### ■ Tray

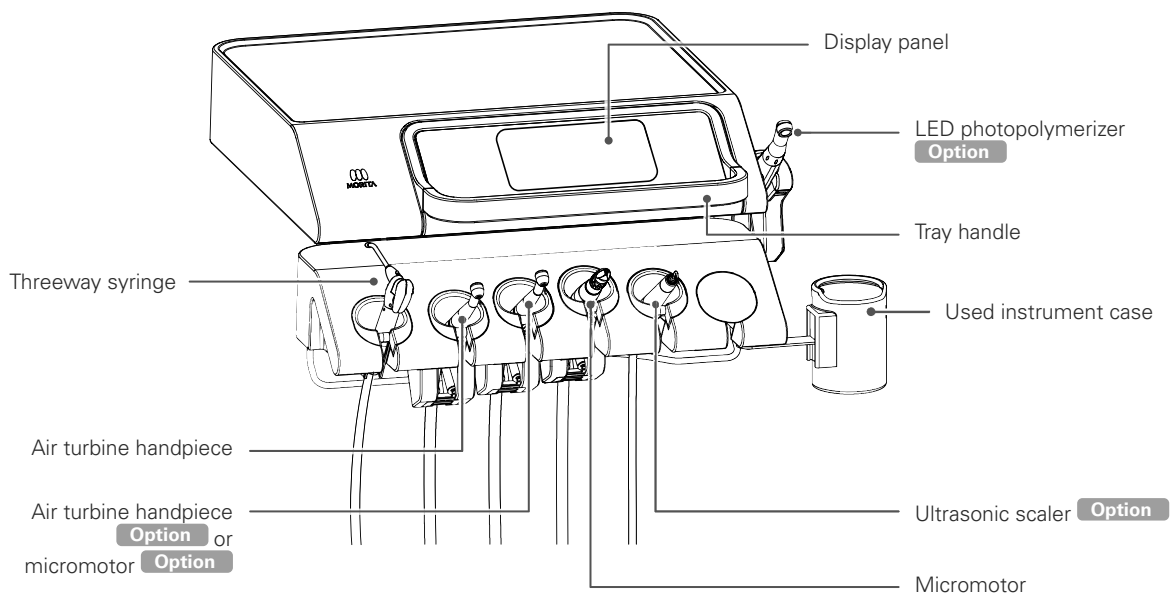

#### ■ Used instrument case

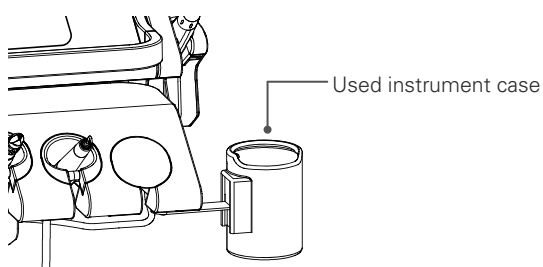

Use the included special paper cup inset in the used instrument case. Replace paper cups with new ones as needed. Dedicated paper cups are available separately. When accessories run out, please place an order with a reseller or the nearest MORITA CORP. subsidiary.

## ■ Tray paper

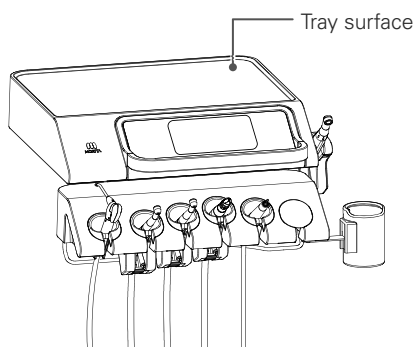

Use by laying on the tray.  
 Replace the tray paper as needed.  
 Dedicated tray papers are available separately. When accessories run out, please place an order with a reseller or the nearest MORITA CORP. subsidiary.

## ■ Silicone tray sheet Option

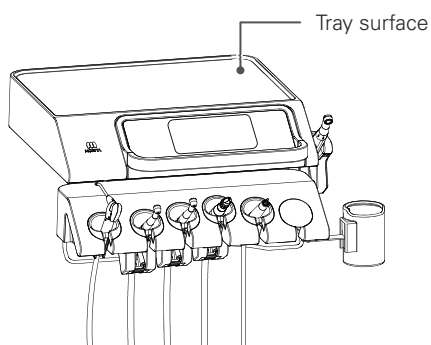

Use by laying on the tray.  
 Autoclave and ethanol cleaning may be used.

## ■ Protective sheet for the operation panel

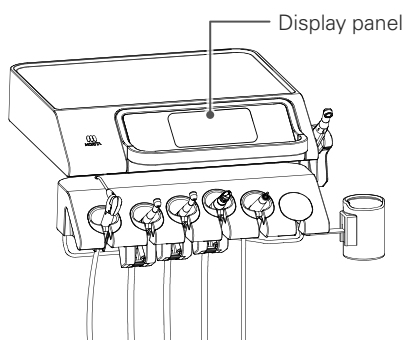

This is a protective sheet for the doctor-side operation panel and the assistant-side operation panel. It adheres to the panel surface and protects against scratches and dirt.

Replace the protective sheet as needed.  
 Protective sheets are also available separately. When accessories run out, please place an order with a reseller or the nearest MORITA CORP. subsidiary.

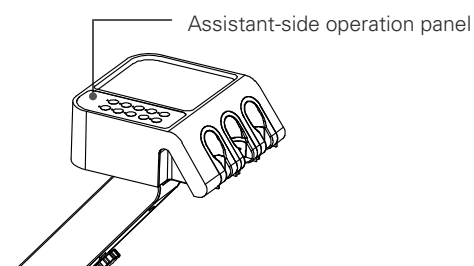

## 4.4.2 Over-the-Patient Tray Type/Floor-mounted Tray Type

### ■ Angle/height adjustment

The tray can be swiveled horizontally and pivoted vertically as shown in the figures below.

Hold the tray handle and move it slowly.

#### Over-the-patient tray type

Horizontal movable range

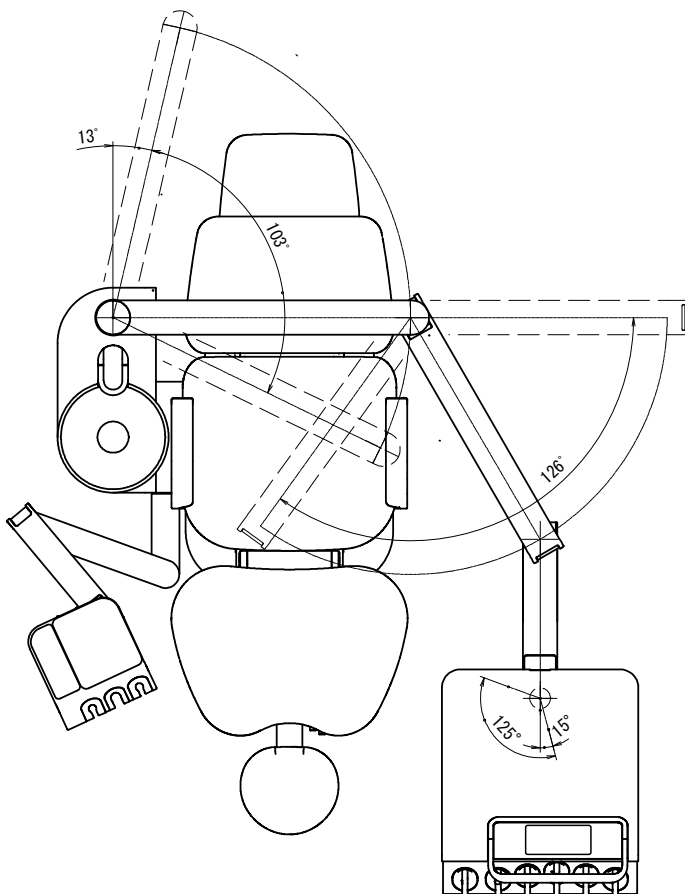

Vertical movable range

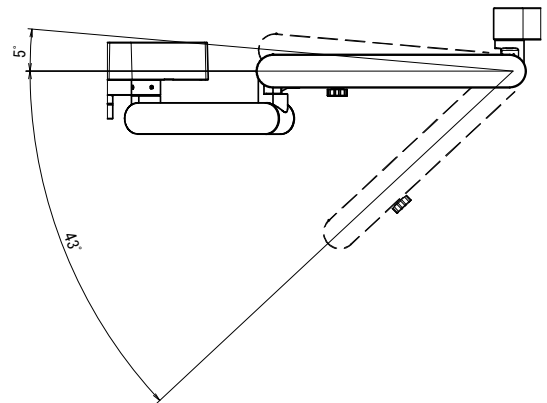



## Floor-mounted tray type

Horizontal movable range

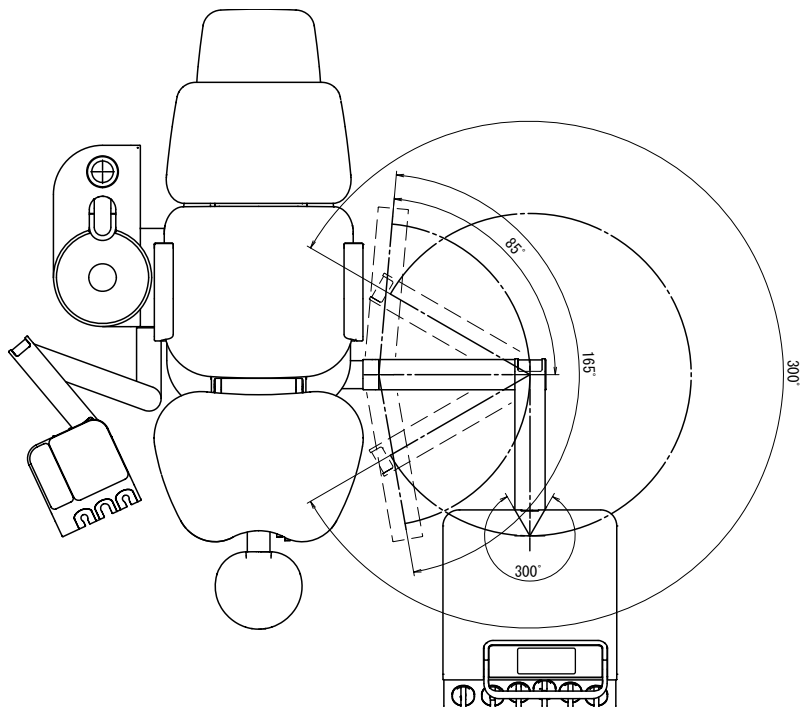

Vertical movable range

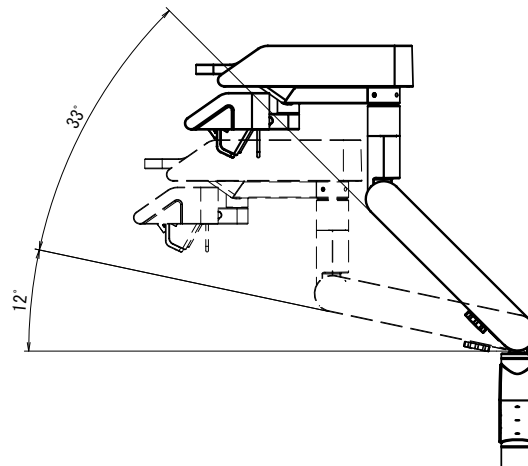

## ■ Adjustment of the force required to move the tray movable arm

You can adjust the force required to move the tray movable arm (below: movable arm) up and down to suit the weight of the objects being placed on the tray.

Follow the procedure below.

- ① When placing heavy objects on the tray, tighten the knob of the movable arm part. The force required to move the tray increases.
- ② When placing light objects on the tray, turn loosen the knob of the movable arm part. The force required to move the tray decreases.
- ③ To fix the vertical position of the tray, tighten the knob fully. This will fix the position of the movable arm, ensuring the tray does not move up or down. To release the tray, loosen the knob.

If the movable arm has been fixed in a low position, the tray may jump upward when the knob is loosened.

Always hold the tray handle when carrying out such adjustments.

Take care not to loosen the knob too much. It can come off and allow structural parts to drop off.

### Over-the-patient tray type

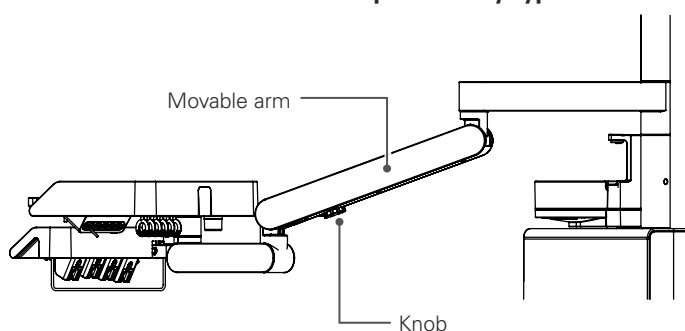

### Floor-mounted tray type

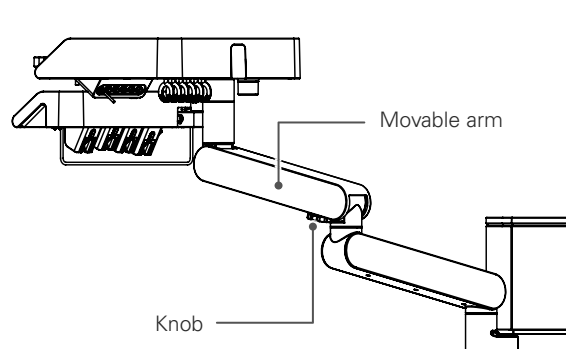

### 4.4.3 Cart

#### ⚠ WARNING

!	<p>Observe the following when operating the cart to ensure it is safe at all times.</p> <p>① Alert passersby/patients to the presence of the hose from the chair on the floor to prevent tripping.</p> <p>② Do not move the cart with excessive force, rest your hands on it, stand items up on the tray, apply an unbalanced load, or engage in any other dangerous behavior.</p> <p>③ Do not pull the hose, drag the cart by pulling the hose, forcibly bend the hose, or damage the hose by stepping on it etc.</p> <p>● This may cause damage/faults.</p>
	<p>Always be sure to use the cart on a level floor. Do not use the cart if it is tilted or has been knocked over.</p> <p>● If the cart is tilted by 10° or more or if it is used where there is a difference in level, it may topple over and cause an accident or damage.</p>
	<p>Always fully tighten the fixing knob.</p> <p>● If insufficiently tightened, the tray may unexpectedly drop and cause an accident or damage.</p>

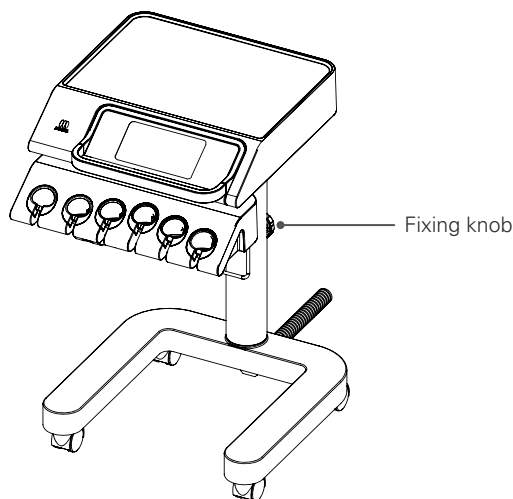

### ■ Operation

The cart can be freely positioned using the leg casters. Hold the tray handle and move it slowly.

### ■ Height Adjustment of Tray Surface

The height of the tray surface can be adjusted between a lowest position of 750 mm and a highest position of 950 mm. Follow the procedures below.

- ① With the doctor-side tray firmly supported, loosen the fixing knob on the support column.
- ② Set the tray to the desired height and re-tighten the fixing knob.

#### 4.4.4 Auxiliary Tray Option

### ⚠ CAUTION

!	<p>When raising the chair, move the auxiliary table to a safe position so that the patient and the chair do not contact the auxiliary table.</p> <ul style="list-style-type: none"> <li>● This may cause injury and faults.</li> </ul>
⊘	<p>Do not load more than 10 N (1 kgf) on the auxiliary table.</p> <p>Also, the load on the auxiliary table and the table should not exceed 30N (3 kgf) in total.</p> <ul style="list-style-type: none"> <li>● This may cause faults</li> </ul>
⊘	<p>Do not lean on the auxiliary tray.</p> <ul style="list-style-type: none"> <li>● This may cause injury and faults</li> </ul>

### ■ Operation

The auxiliary tray rotates 180°  
Move to any position and use.

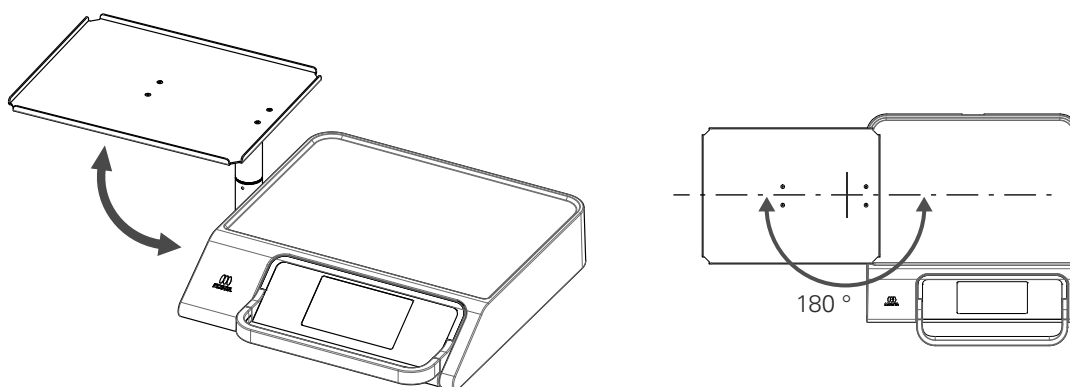

When the chair is lowered and the auxiliary table is loaded downward, the safety switch operates and the chair stops. Remove the load and try again.

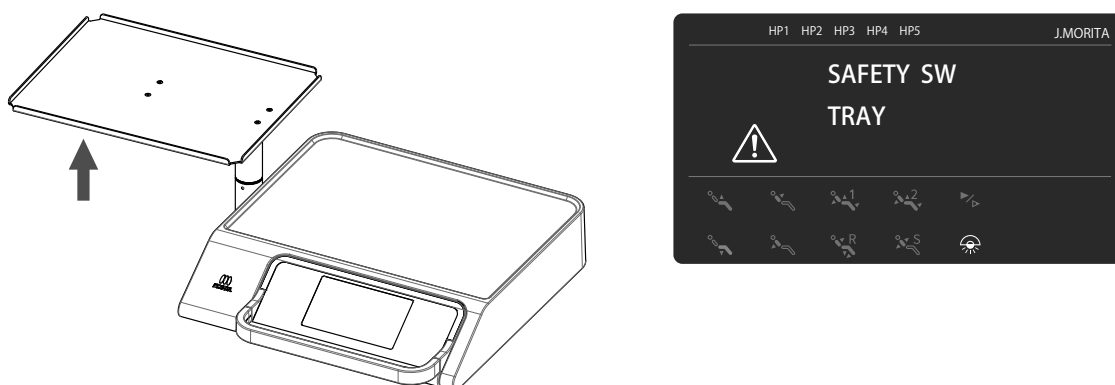

## 4.5 Instrument Holder

<b>⚠ CAUTION</b>	
<b>!</b>	When operating the chair, always be sure to operate the instrument holder and arm in a way which avoids the seat and backrest. ● Damage and faults may occur if the chair is operated while the instrument holder and arm are over the seat or backrest.
	To alter the position of the instrument holder, slowly move the instrument holder while firmly holding the tray handle. ● Holding and pulling the instrument portion and holder tip when done forcefully may cause damage and faults.
<b>⊘</b>	Do not apply a load of 10 N (1 kgf) or more to the assistant-side auxiliary tray. ● This may cause damage/faults.
	Do not apply a load to the main tube (by pulling the tray by the main tube or by forcefully pulling the tube when wiping it). ● This may cause air leaks/water leaks and damage/faults.

### 4.5.1 Doctor-side Holder

<b>⚠ CAUTION</b>	
<b>⊘</b>	Do not forcefully pull or remove the main tube, roller, or holder cup from the holder. ● Not following the correct procedure may result in damage or a fault.

#### ■ Doctor-side holder

Move the instrument holder horizontally.  
Move it by placing your fingers in the side recess and pulling gently.

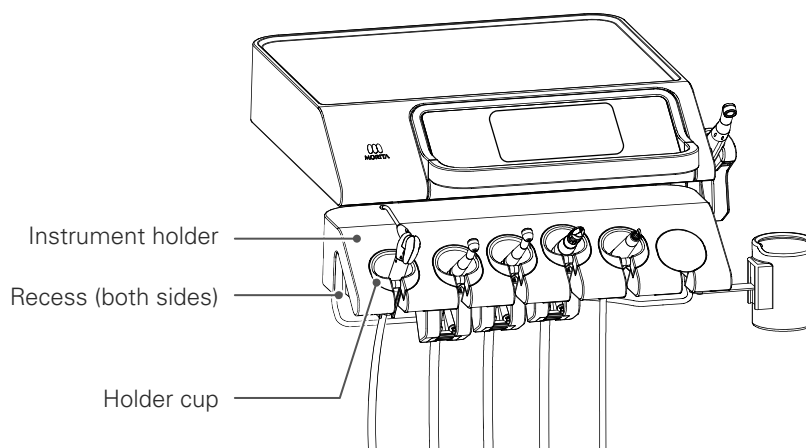

## 4.5.2 Assistant-side Holder

### ⚠ CAUTION

<p>⊘</p>	<p>Do not put heavy objects on the assistant-side arm and do not apply excessive force by performing sudden movement etc.</p> <p>Do not sit on the arm, rest your hands on it, or put your feet on it, etc.</p> <p>Do not forcibly insert the nozzle while the syringes are in the holder.</p> <p>● This may result in accidental injury or a fault.</p>
<p>!</p>	<p>When operating the assistant-side holder and arm, always ensure that it is safe.</p> <p>① Do not allow hands, parts of the body/baggage etc. to come close to the movable parts of the arm (grasp the arm, touch the base of the holder etc.)</p> <p>② Do not allow the patient to touch it (mischievous pranks of children, leaning against it)</p> <p>③ Do not place items/appliances that could impede movement within range of the arm.</p> <p>④ Do not behave in a way that could be considered dangerous</p> <p>⑤ Do not operate in a situation that could be dangerous</p> <p>● Failure to check could result in injury, damage/faults.</p>

### ■ Assistant-side holder

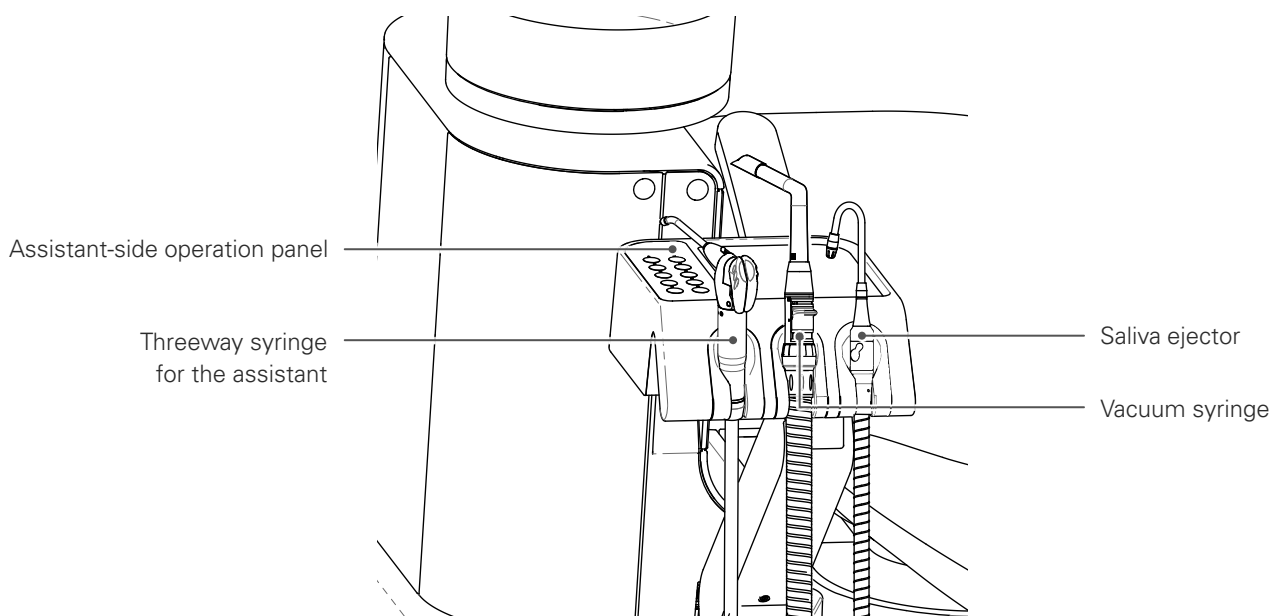

### Arm Movable Range

The holder can be moved with the balance arm and it can be arranged depending on the type of treatment.

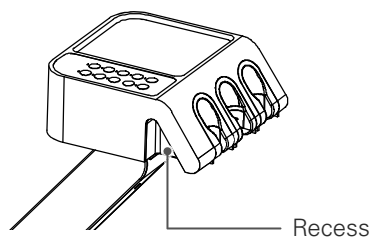
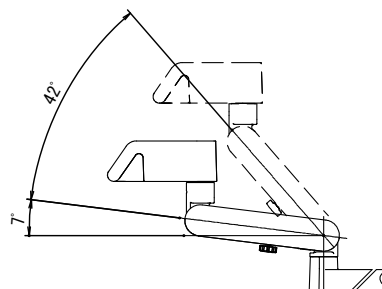
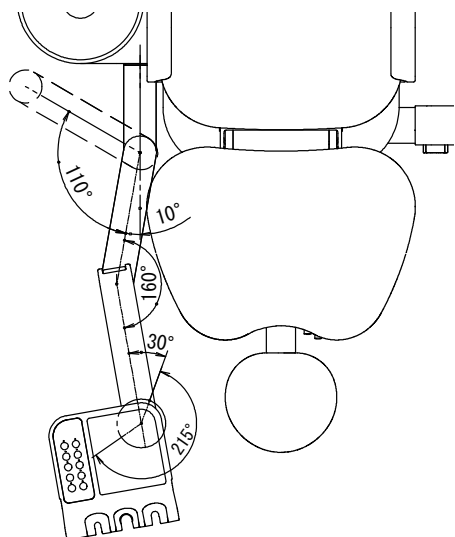

When moving the holder and arm, place your fingers in the hollow in the sides of the holder (both sides) and move it gently.

### Fixing the Arm Angle

Adjust the angle of the balance arm and fix its position.

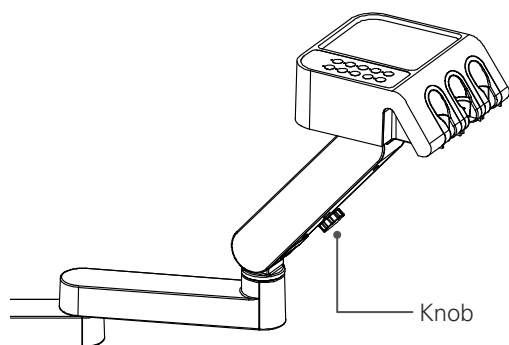

Adjust the angle of the balance arm and fix its position.

Loosen the knob on the arm, move the arm to the desired position, and tighten the knob to fix the arm angle.



To move the arm again, loosen the knob and move it.

If the movable arm has been fixed in a low position, the holder may jump upward when the knob is loosened. Always hold the holder before making the adjustment.

Take care not to loosen the knob too much. It can come off and allow structural parts to drop off.

If the knob has been tightened, do not forcibly move the balance arm. The internal mechanism may break.

### Assistant-side Tray

 CAUTION	
	Do not apply a load of 10 N (1 kgf) or more to the assistant-side auxiliary tray.
	Do not place drug bottles, ethanol lamps (mainly liquids etc.) on the assistant-side auxiliary tray.
	<ul style="list-style-type: none"> <li>● Sudden dropping of the arm may cause a collision and damage/faults.</li> <li>● There is a danger that the arm will drop during operation and cause an accident. It may also cause discoloration of the appearance due to adhesion and cause a fault due to internal contamination.</li> </ul>

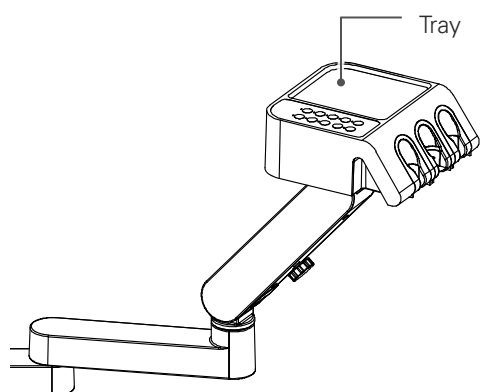

When using the tray, be careful not to interfere with the operation of the instrument.

Always be sure to fix the arm angle before placing objects on the tray.

## 4.6 Instruments

<b>⚠ WARNING</b>	
	<p>For how to connect and use the air turbine, micromotor, ultrasonic scaler etc., always follow the operation instructions supplied with the relevant product.</p> <ul style="list-style-type: none"> <li>● Improper handling may cause accidents and faults due to unforeseen circumstances.</li> </ul>
<b>!</b>	<p>When putting instruments into the holders, do so gently and carefully. If an instrument is not put back securely, it may not be selected correctly.</p> <ul style="list-style-type: none"> <li>● This may cause accidents/problems and faults.</li> </ul>
	<p>If significant expansion occurs in the main tube while the air turbine is being used, immediately stop using it and check the state of the exhaust.</p> <ul style="list-style-type: none"> <li>● If the exhaust tube ruptures or clogs, continued use may lead to expansion and rupture of the main tube, and an accident/fault may occur.</li> </ul>
	<p>Be sure the handpiece bar has stopped rotating before putting the handpiece into the patient's mouth.</p> <ul style="list-style-type: none"> <li>● There is a risk of injury.</li> </ul>
<b>⊘</b>	<p>Do not bend the main tube while using instruments, especially when using the air turbine.</p> <ul style="list-style-type: none"> <li>● If you continue use it while bent, this may lead to expansion and rupture of the main tube, causing an accident/fault.</li> </ul>
<b>⚠ CAUTION</b>	
<b>!</b>	<p>Pay careful attention when jetting air onto the gingiva of the patient, and promptly take appropriate action if an abnormality occurs.</p> <ul style="list-style-type: none"> <li>● When air is used on the gingiva, complications such subcutaneous emphysema can occur.</li> </ul>
<b>⊘</b>	<p>Keep heaters away from the device. Also, make sure that it is not exposed to warm air directly.</p> <ul style="list-style-type: none"> <li>● Heat softens and expands the tube, causing breakage or other damage.</li> </ul>

### 4.6.1 Water Tank Option

Water for each instrument's water injection is supplied from the water tank attached to the pillar.  
For the usage of the water tank, please operate according to the attached instruction manual.  
However, adjust the pressure to 0.2MPa (200kPa) .

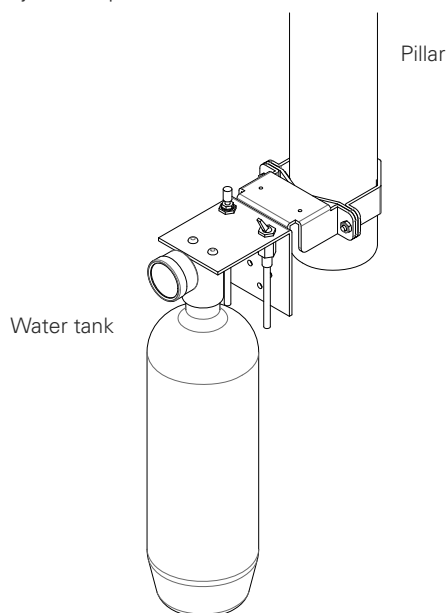



## 4.6.2 Water Supply Rate Adjustment

The instrument water supply rate can be adjusted. The air flow rate for the threeway syringe can also be adjusted.

### ■ Doctor-side instruments

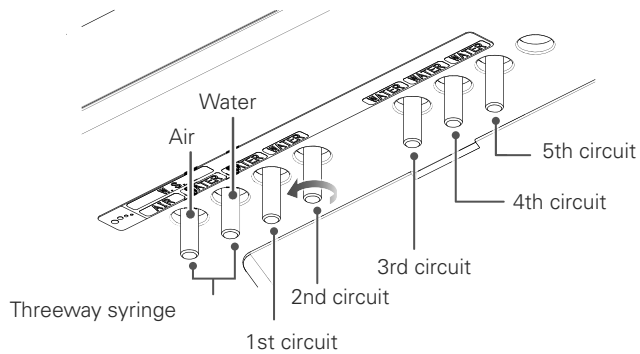
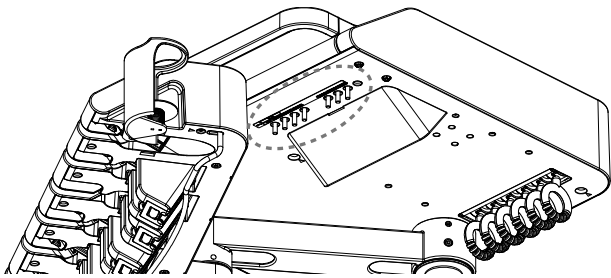

Adjust using the valve on the underside of the tray.  
Turn in the direction of the arrow to increase the water flow rate and air flow rate.

### ■ Assistant-side threeway syringe

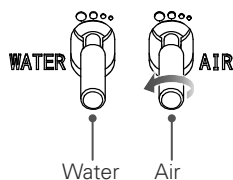
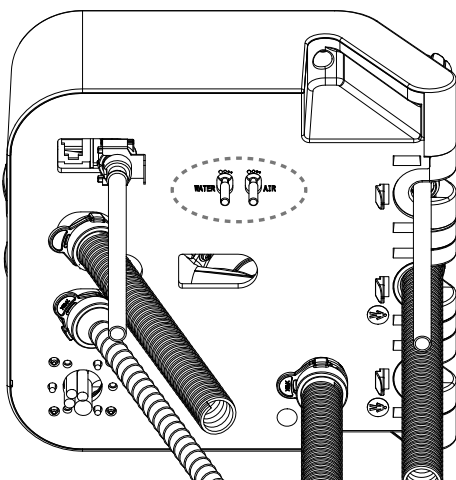

Adjust using the valve on the lower surface of the assistant-side holder.  
Turn in the direction of the arrow to increase the water flow rate and air flow rate.

### 4.6.3 Foot Control Operation (extended function) Option

The foot control with extended functions enables you to perform the following operations while holding an instrument.

#### ■ Switching Range

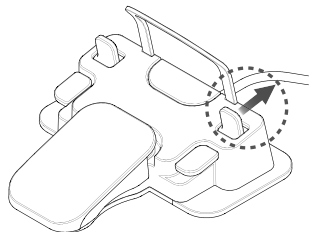

Operate the lever in the direction of the arrow.  
The instrument range will change.

- Micromotor
- Ultrasonic scaler

#### ■ Instrument light ON/OFF

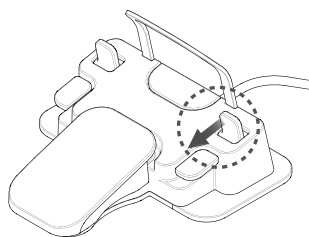

Operate the lever in the direction of the arrow.  
Switches the instrument light ON/OFF and changes the illumination. (OFF, ON, ON [BRIGHT])

#### ■ Switching direction of rotation

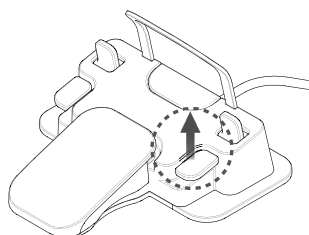

Operate the lever in the direction of the arrow.  
Changes the direction of rotation of the micromotor.

#### ■ Switching water flow

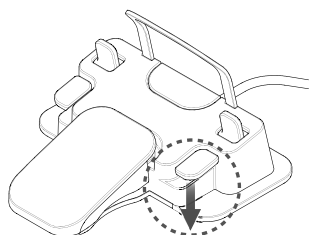

Operate the lever in the direction of the arrow.  
Switches instrument water flow ON/OFF.

## 4.6.4 Common Settings for Instruments

Perform common settings for the air turbine handpiece, micromotor and ultrasonic scaler.  
Settings are performed with the instruments picked up.



Example: picking up the air turbine handpiece

Perform settings for the air turbine handpiece, micromotor and ultrasonic scaler on the respective pickup screens.



### Instrument light settings

Switch the instrument light ON/OFF and change between 2 brightness levels.

Press to toggle between OFF, L(low brightness) and H (high brightness).

Note that this function is not available on specifications lacking a light (lamp part of instrument remains OFF).



### Instrument water flow ON/OFF

Switch instrument water flow ON/OFF.

Press to toggle the water flow ON/OFF.



### Toggling between instrument constant speed/variable speed.

Change the rotation speed of the instrument.

Press the constant speed/variable speed switchover icon to toggle between variable speed (VER) and constant speed (FIXED).

Constant speed: the speed of rotation (maximum speed) is constant regardless of the pressure on the foot pedal.

Variable speed: the speed of rotation varies according to the pressure on the foot pedal.

## 4.6.5 Air Turbine Handpiece

For details on how to use the air turbine handpiece, be sure to read the separate operation instructions.

### ■ Starting and Stopping Rotation

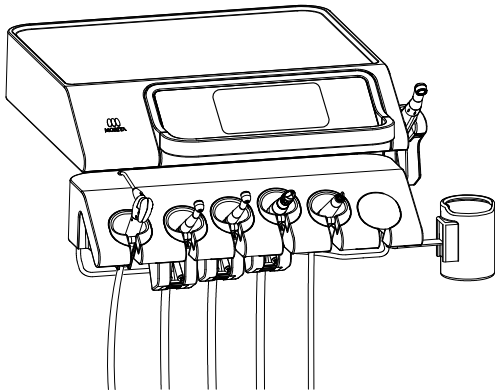

- ① Pick up the air turbine handpiece from the instrument holder. At this point, the circuit of the instrument you pick up first takes priority. Picking up another instrument will not change the circuit selection.

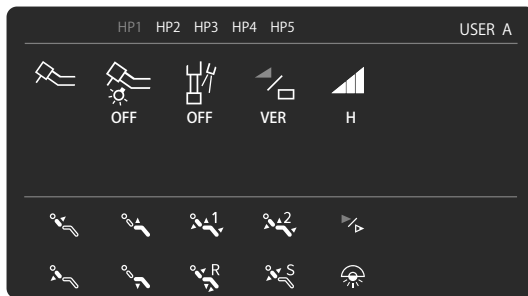

- ② The settings screen for the air turbine handpiece is displayed on the display panel.

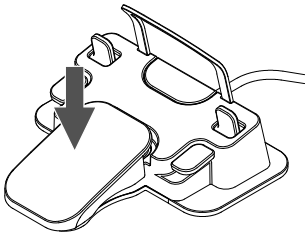

- ③ Step on the foot control pedal to operate the air turbine at a constant speed and release the pedal to stop.  
The level bar on the display panel will show the maximum level during rotation.  
The constant speed/variable speed switchover icon goes blue.

Chair operation is not possible while the micrometer is running.

## ■ AI Catch Function

This is a function for supporting the weight of the tube at the tube port to reduce stress on the wrist when using the handpiece. Switching ON/OFF, AI catch timing (0-9.9 seconds), AI catch release timing (0-9.9 seconds) can be set.

### Various Settings

- AI catch ON/OFF setting p. 106
- AI catch/timing delay period setting p. 106
- AI catch/release delay period setting p. 107

## ■ Clean air system Option

Prevents the suction effect that occurs when rotation of the air turbine stops, and prevents ingress of cutting debris, soiled waste etc. into the air circuit.

Expels a small amount of air for about 10 seconds when the air turbine stops.

## ■ Variable Speed Option

The rotation speed varies depending on how deeply you press the foot control pedal.

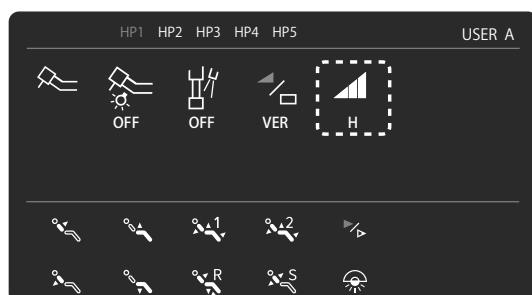

Press the range icon to switch the range in 3 steps (L, M, H). The instrument rotates at variable speed within each range.



The corresponding estimated maximum rotation speeds are displayed on the display panel.

Because the actual air turbine rotation speed is varied by varying the air pressure, it may not exactly match the displayed speed.

## ■ Air Scaler Option

This is an air scaler that can be attached to the air turbine circuit.  
Vibration can be performed using the same operations as for the air turbine.

## ■ Various Settings

Various settings and changes can be made.  
For settings, refer to the following sections.

- Switching water flow ON/OFF ☞ p. 49
- Switching the light ON/OFF, changing brightness level ☞ p. 49
- Setting the water injection timing ☞ pp. 105-107
- Switching between variable speed/constant speed ☞ p. 51

## 4.6.6 Micromotor

### ⚠ CAUTION



Do not apply repeated sudden loads or lock the micromotor while it is rotating.  
 ● The micromotor may overheat and cause a fault.

For details of how to handle the micromotor, be sure to read the separate operation instructions.

### ■ Starting and Stopping Rotation

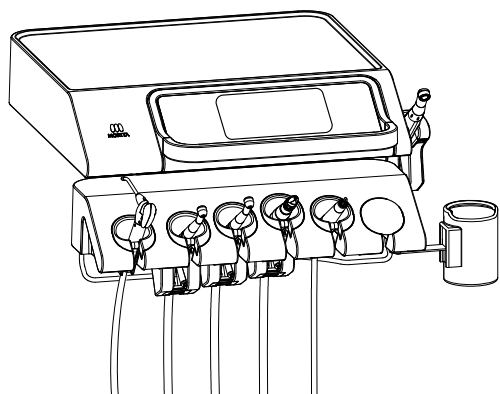

- ① Pick up the micromotor from the instrument holder.  
 At this point, the circuit of the instrument you pick up first takes priority.  
 Picking up another instrument will not change the circuit selection.

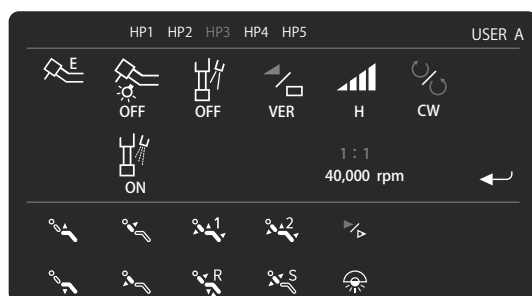

- ② The settings screen for the micromotor is displayed on the display panel.

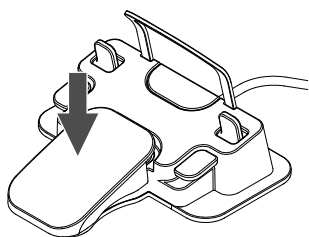

- ③ Step on the foot control pedal to start the micromotor and release the pedal to stop.

Chair operation is not possible while the micrometer is running.

## Range Selection

Select a range.



- ① Press the range icon to switch the range in 4 steps (UL, L, M, H). The instrument rotates at variable speed within each range. The corresponding estimated maximum rotation speeds are displayed on the display panel.



## Switching Direction of Rotation

Switch the direction of rotation.

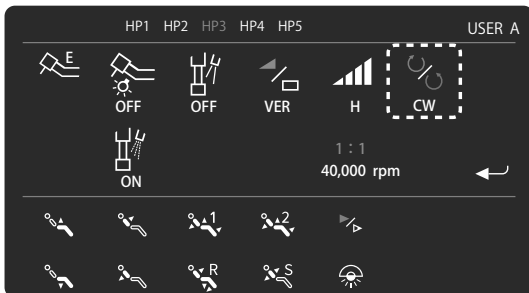

- ① Press the forward/reverse icon to toggle between forward rotation (CW) and reverse rotation (CCW).





## Speed Up Ratio/Speed Reduction Ratio Selection

Select the speed up ratio/speed reduction ratio for the attachment.

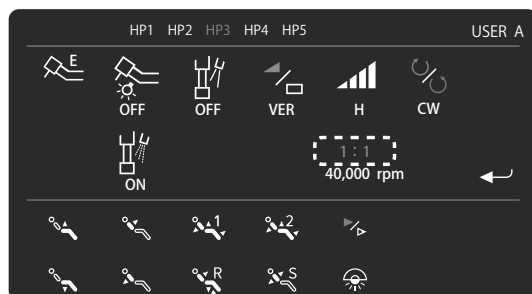

- ① Press the speed up ratio/speed reduction ratio icon on the micromotor settings screen.



- ② The speed up ratio/speed reduction ratio settings screen will appear. Press "SPEED UP" to select the preset speed up ratio. Press "SPEED REDC" to select the preset speed reduction ratio. To alter the value of the speed up ratio and speed reduction ratio, refer to "Micromotor Speed Up Ratio/Speed Reduction Ratio Settings" p. 103. To set the equal speed setting from the speed up setting or speed reduction setting, press "1: 1".

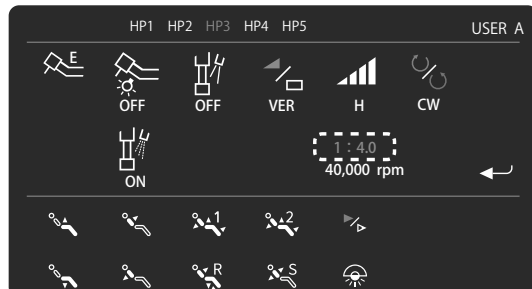

- ③ On selection, the settings screen reappears. The selected speed up or speed reduction ratio will now be displayed.

## ■ Setting the Rotation Speed

You can switch between 4 ranges (UL, L, M, H) using the range changeover icon and further adjust the speed within each range. The upper limit of the rotation speed can be set for constant speed and variable speed.

The displayed rotation speed is an estimate of the micromotor speed calculated based on the speed up ratio/speed reduction ratio of the attachment and may not exactly match the actual rotation speed.

### Constant Speed

Rotates at a constant speed when the foot control pedal is stepped on.

The settable upper limit speeds are as follows.

Range	Rotation speed (min <sup>-1</sup> )
UL	300
L	5,000
M	20,000
H	40,000

### Variable speed:

The rotation speed varies depending on how deeply you press the foot control pedal.

The available variable speeds are as follows.

Range	Rotation speed (min <sup>-1</sup> )
UL	100-300
L	100-5,000
M	100-20,000
H	100-40,000

### Setting the Rotation Speed



① Press the rotation speed icon.



② The rotation speed settings screen will appear.

Use the + and- symbols to increase or decrease the rotation speed setting.

Note that speed setting increases in steps of 10 min<sup>-1</sup> for below 1000 and in steps of 100 min<sup>-1</sup> at 1000 or higher.

Long press the + and- symbols to increase or decrease in steps of 100 min<sup>-1</sup> and 500 min<sup>-1</sup> respectively.

Press Enter to confirm and return to the micromotor settings screen.

The rotation speed can be set for each range.

## ■ Chip air ON/OFF

Chip air ON/OFF can be set.  
Can be set for each range.

The micromotor may become hot if it continues to be used while chip air is OFF. Chip air should normally be ON when using the micromotor.

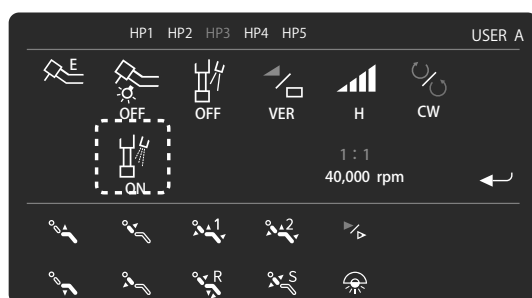

☞ Press the chip air icon to toggle chip air ON/OFF.

## ■ Various Settings

Various settings and changes can be made.  
For settings, refer to the following sections.

- Switching water flow ON/OFF ☞ p. 49
- Switching the light ON/OFF, changing brightness level ☞ p. 49
- Setting the water injection timing ☞ pp. 104-105
- Switching between variable speed/constant speed ☞ p. 51
- Switching the direction of rotation ☞ p. 54
- Range changeover ☞ p. 54

## 4.6.7 Threeway Syringe

<b>⚠ WARNING</b>	
<b>⚡</b>	When using hot water, be sure to check that the temperature is correct before use. <ul style="list-style-type: none"> <li>● The temperature of the warmer may rise considerably due to overheating or the effects of external air temperature and accidents such as scalding and damage/faults may occur.</li> </ul>
<b>⚠ CAUTION</b>	
<b>!</b>	If hot water is not needed, turn the warmer switch OFF. <ul style="list-style-type: none"> <li>● Overheating of the heater may shorten the life of the tube or heater and lead to damage and faults.</li> </ul>
<b>⊘</b>	Keep heaters such as fan heaters and oil heaters close to each other, or make sure that warm air does not hit them directly. <ul style="list-style-type: none"> <li>● Heat softens and expands the tube, causing breakage or other damage.</li> </ul>

### ■ WS97

#### Operation

When the water lever and air lever are operated, water, air and spray will be emitted.

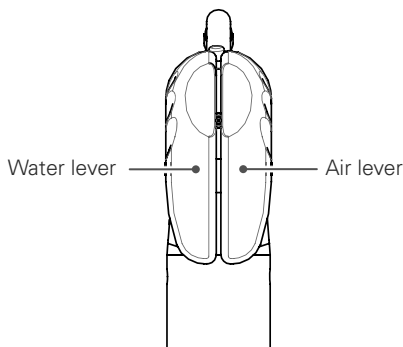

Water lever: emits water.

Air lever: emits air.

Water and air levers pressed together: emits a spray.

#### Removing and attaching the nozzle and syringe body

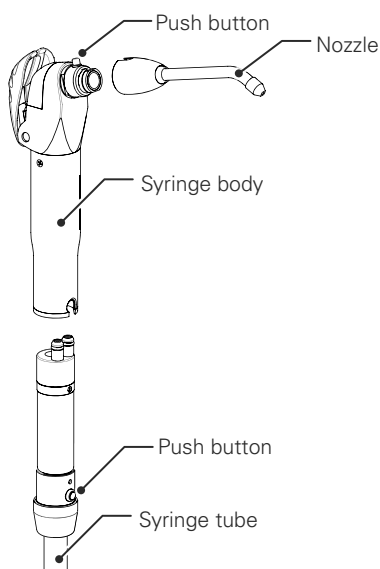

Both the nozzle and body can be autoclaved and removable.

##### Removing and attaching the nozzle

Hold down the push button for the syringe body and pull out the nozzle from the syringe body.

To reattach it, push it straight in until it clicks into place.

Connect the nozzle to the syringe body securely. It may unexpectedly pop out if it is not connected securely.

##### Removing and attaching the syringe body

Hold down the push button for the syringe tube and pull the syringe tube out of the syringe body.

To reattach it, push it straight in until it clicks into place.

Connect the syringe body to the syringe tube securely. It may unexpectedly pop out if it is not connected securely.

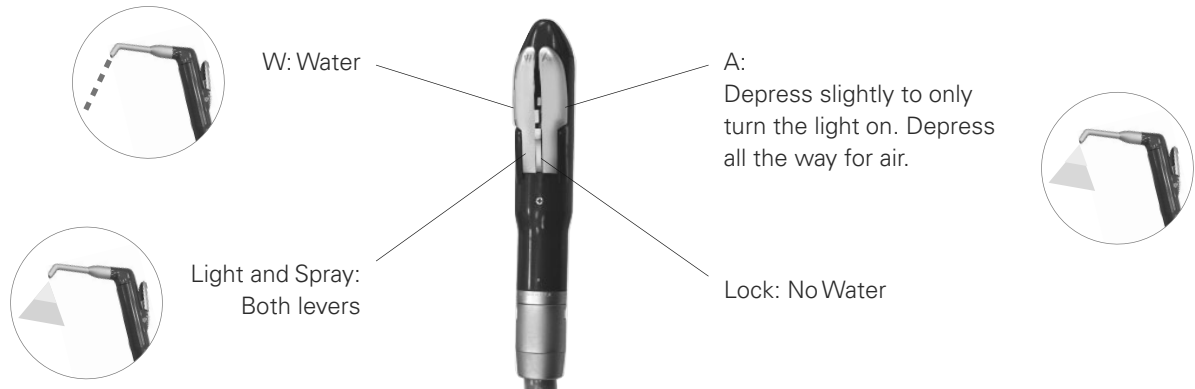

## ■ WS10-O-LD Option

### Operation



Always lock the water lever before putting the syringe away to prevent leaking.

### Connection/removal of nozzle and syringe case

 CAUTION	
	Make sure there is an audible click when putting the nozzle on the threeway syringe and that the nozzle is securely fixed to the syringe.
	Remember that the LED and its cover are extremely hot right after the LED has been turned off. Do not touch these parts; they could cause a burn.
	Make sure the threeway syringe case and body are securely attached to each other. Otherwise, the case could slip off when you take it out of its holder.
	If the nozzle gets plugged up with debris, it could be blown off the end of the syringe during use and injure someone.

### Removing and inserting the nozzle

Push the nozzle into the syringe or pull it out.

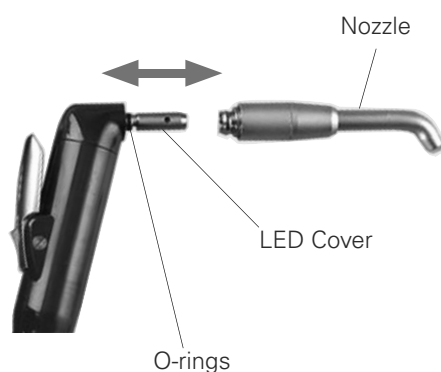

- A little water may come out of the threeway syringe when the air lever is pressed right after the nozzle has been attached. Press the air lever 2 or 3 times to expel all the water.
- Coat the O-rings with vaseline if it is hard to attach and remove.

### Putting on the syringe case

Match the marks on the syringe case and the syringe body, and push them together until they click. Make sure the syringe case is securely connected.

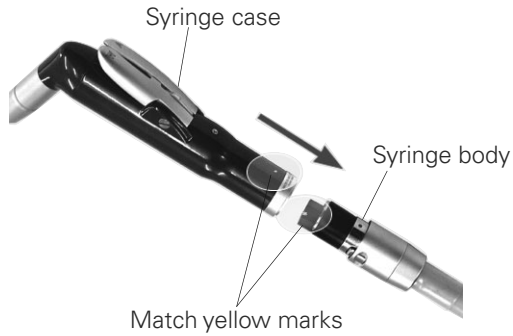

### Taking off the syringe case

Press down on the indented part of the syringe tube connector and pull the syringe case off the syringe body.

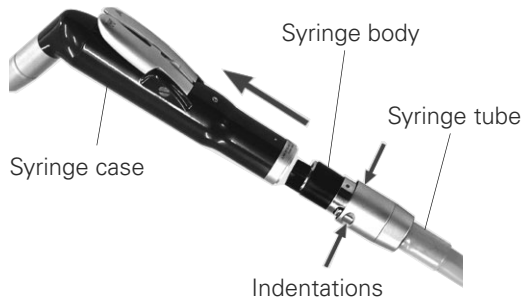

## ■ WS100 Option / WS100LD (with light) Option

### Operation

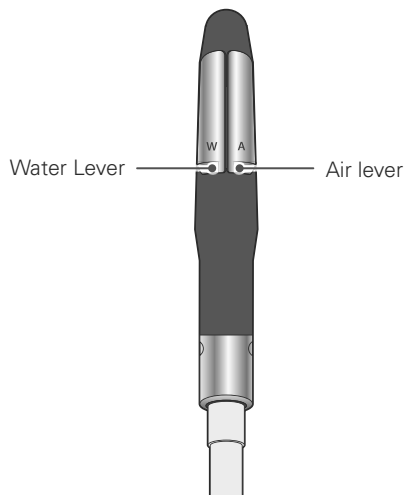

#### WS100

- Water lever: water is emitted
- Air lever: air is emitted.
- Water and air levers pressed together: spray is emitted.

#### WS100-LD (with light)

- Water lever: water is emitted
- Air lever: press gently to turn the light ON and press firmly to emit air.
- Water and air levers pressed together: the light comes on and a spray is emitted.

Continuous illumination with the light alone may cause the main unit to become hot and cause burns. If it gets hot, let it cool by emitting air for at least 30 seconds.

## ■ Attaching the syringe case and nozzle

The nozzle, syringe case, and syringe body are different parts for WS100 (without light) and WS100-LD (with light). Connect with the correct combination.

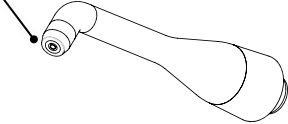
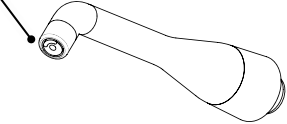
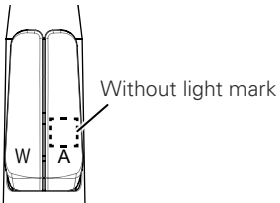
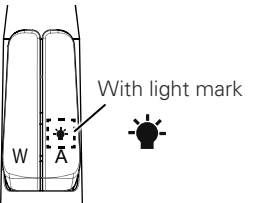
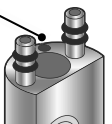
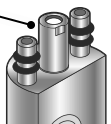
	WS100 (without light)	WS100-LD(with light)
Nozzle	Without light irradiation mark 	With light irradiation mark 
Syringe Case	Without light mark 	With light mark 
Syringe Body	Without LED 	With LED 

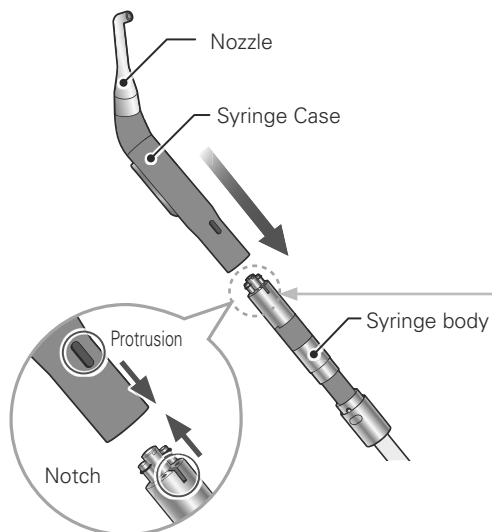

Align the protrusion on the syringe case with the notch on the syringe body and insert it straight until it clicks.

Connect the syringe case to the syringe body securely. It may unexpectedly pop out if it is not connected securely.

Also connect the nozzle securely.

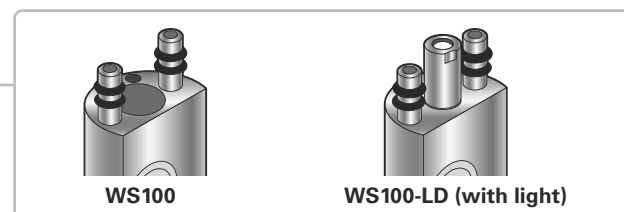

After connecting the nozzle, press the air lever several times and drain the water. Water in the nozzle may get mixed in with air.

## ■ Removing the Syringe Case

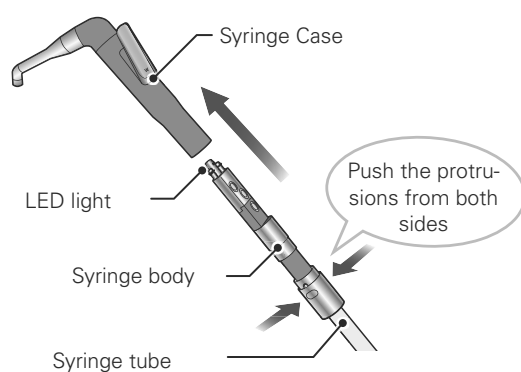

Withdraw the syringe case from the syringe body while pressing the recess in the syringe tube joint from both sides.

Do not touch the light immediately after it is turned off because the LED light and surroundings may be hot.

## 4.6.8 Vacuum Syringe

Suck out cutting debris and water from the oral cavity.

### ■ Vacuum syringe (VS110)

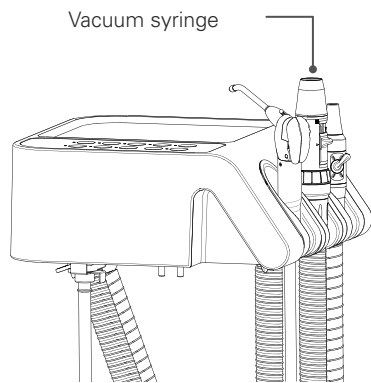

#### Starting and Stopping Suction

- ① Suction starts automatically when the vacuum syringe is picked up from the instrument holder.  
Suction stops when it is placed in the instrument holder.
- ② Suction temporarily stops when the vacuum suction switch on the assistant operation panel is pressed during suction.  
Press again to resume suction.

Even if it is placed in the instrument holder with the suction stopped, suction starts when the vacuum syringe is picked up from the holder again.

#### Suction Strength Adjustment

The suction rate changes when the adjustment lever is slid.

When wrapping the adjustment lever with plastic etc., avoid moisture oozing out under the effects of pressure during suction.

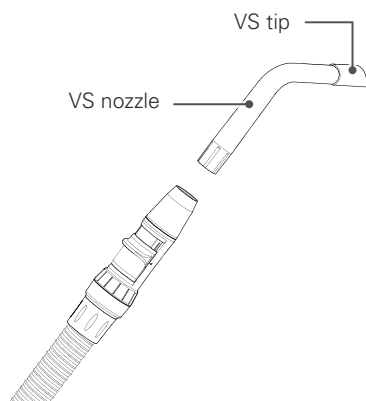
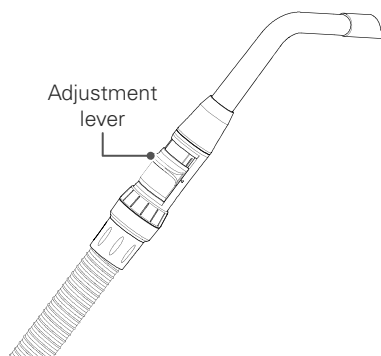

#### VS nozzle connection

Insert the VS tip firmly into the VS nozzle tip, and then insert it straight into the tip of the syringe.

Hold the syringe body firmly when inserting it.  
An improper connection may result in damage.

If insertion of the VS nozzle or the VS tip is insufficient, it may disconnect during use.

The standard connection is a  $\phi 16$  nozzle, but other nozzles with different diameters ( $\phi 10$  or  $\phi 11$ ) can be connected by replacing the tip of the syringe (conversion adapter **Option**).



**■ Vacuum Syringe Rotary Type (VS110) Option**

The direction of the tip of the syringe can be changed by rotating the base of the vacuum syringe.  
Hold the syringe tube sides, rotate the tip and change the direction.

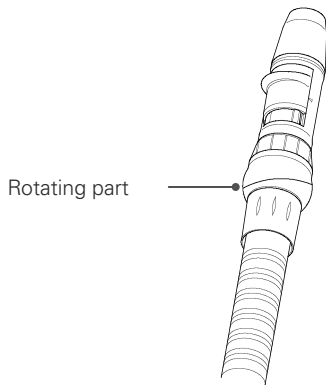

Hold the syringe tube sides, rotate the tip and change the direction.

## 4.6.9 Saliva Ejector

### ■ Saliva ejector (SE110)

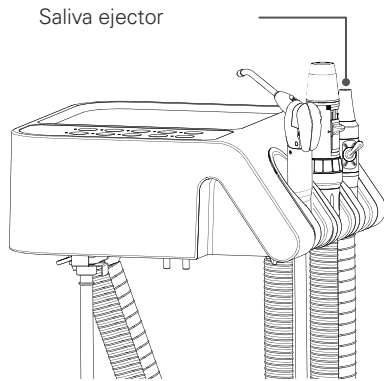

#### Starting and Stopping Suction

Suction starts automatically when the saliva ejector is picked up from the instrument holder.

Suction stops when it is placed in the instrument holder.

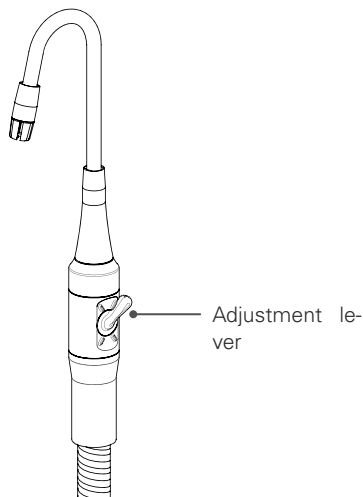

#### Suction Strength Adjustment

The suction strength changes when the adjustment lever is rotated.

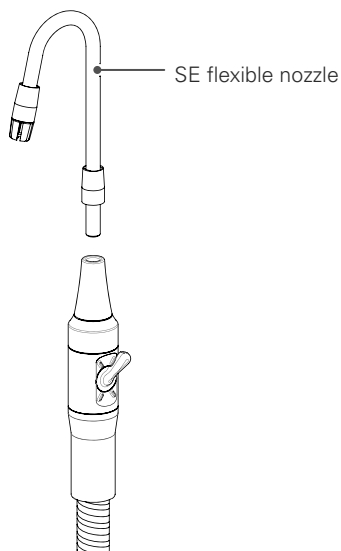

#### SE Flexible Nozzle Connection

Insert the SE flexible nozzle into the rubber part at the tip of the ejector. The SE flexible nozzle can be installed in any orientation.

If the SE flexible nozzle is bent strongly or repeatedly bent, the wire inside may break and there is a possibility that it may pierce the tube surface. Always check the state of the wire and replace it with a new one if it is damaged.

## 4.6.10 Ultrasonic Scaler (Newtron) Option

For details on how to handle the ultrasonic scaler, always read the separate operation instructions.

### ■ Attaching the syringe

**LED without light**

**With LED Light**

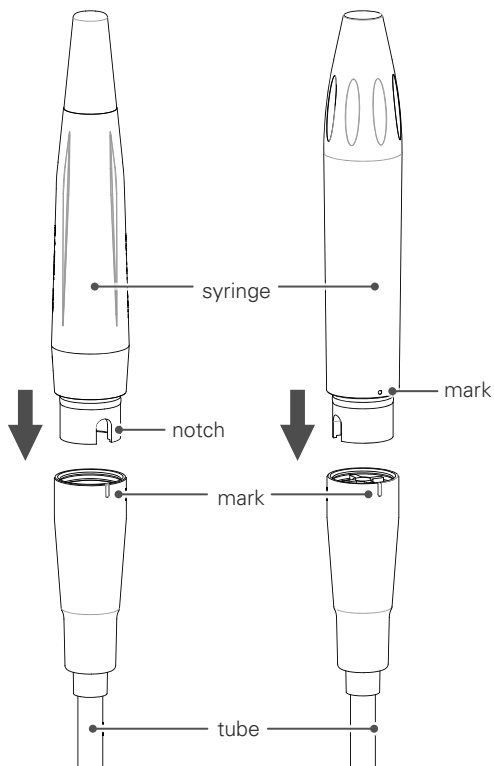

#### **LED without light**

Align the notch on the syringe side with the mark on the tube side and insert the syringe.

#### **With LED Light**

Align the syringe side mark with the tube side mark and insert the syringe.

Please connect the syringe and tube reliably.

It may unexpectedly deviate if it is not securely connected.

## ■ Vibration and Stopping

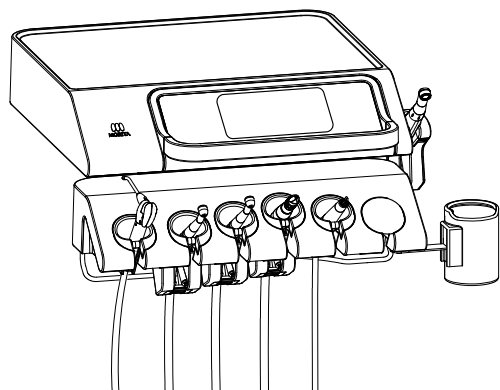

- ① Pick up the ultrasonic scaler from the instrument holder.  
At this point, the circuit of the instrument you pick up first takes priority.  
Picking up another instrument will not change the circuit selection.



- ② The settings screen for the ultrasonic scaler is displayed on the display panel.  
(Example) PERIO

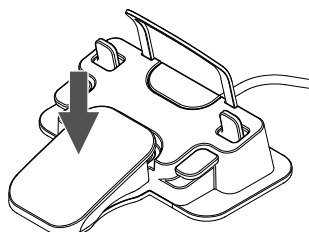

- ③ Step on the pedal on the foot control to start vibration.  
The display panel will display the power bar.  
Take your foot off the pedal to stop the vibration.

During vibration, the chair cannot be operated.

## ■ Changing the Range

Changes the range.



Press the range icon to toggle between “PERIO;” “ENDO;” and “SCALING” in this order.



## ■ Power Adjustment

You can change the power level in each range.

### When picked up



① Press Enter on the ultrasonic scaler settings screen.



② The power change screen will appear.

Press the Up/Down arrows to change the power value.

The power value can be changed from 0.5-10.0 in increments of 0.5.

③ Press Enter to confirm.

### During vibration



Although you can change the numerical power value during vibration, the power itself will not change.

The power will only change when you press on the foot control pedal again.

① When the power bar is displayed during vibration, press Enter to change the power value.

Press the Up/Down arrows to change the power value.

The power value can be changed from 0.5-10.0 in increments of 0.5.

② Press Enter to confirm.

## ■ Various Settings

Various settings and changes can be made.  
For settings, refer to the following sections.

- Switching water flow ON/OFF [▶ p. 49](#)
- Switching the light ON/OFF, changing brightness level [▶ p. 49](#)
- Scaler one-touch mode [▶ p. 102](#)  
(selecting continuous vibration or pedal synchronization)

## 4.6.11 Ultrasonic Scaler (Solfy) Option

For details of how to handle the ultrasonic scaler, always read the separate operation instructions.

### ■ Vibration and Stopping

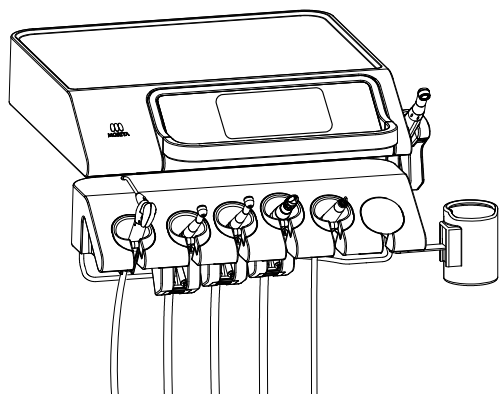

- ① Pick up the ultrasonic scaler from the instrument holder.  
At this point, the circuit of the instrument you pick up first takes priority.  
Picking up another instrument will not change the circuit selection.

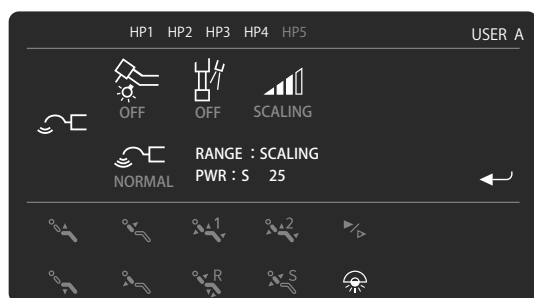

- ② The settings screen for the ultrasonic scaler is displayed on the display panel.

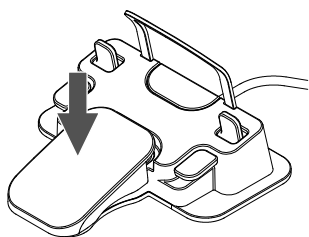

- ③ Step on the pedal on the foot control to start vibration.  
The display panel will display the power bar.  
Take your foot off the pedal to stop the vibration.

During vibration, the chair cannot be operated.

### ■ Changing the Range

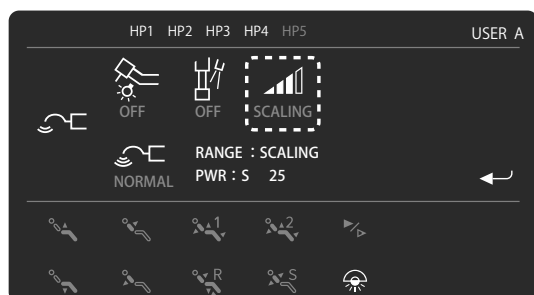

Press the range icon to toggle between "PERIO", "ENDO", "SCALING" and "BOOST" in this order.

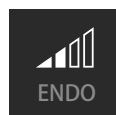

## ■ Changing the Vibration Mode

The vibration mode can be changed for each range.



Press the vibration mode icon to toggle between “NORMAL” “SOFT” and “OFF”:

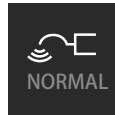

### Normal Mode

Constant power is maintained to allow effective removal of calculi etc.

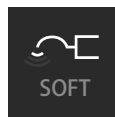

### Soft Mode

The vibrations soften according to the tip force applied to the tooth to allow gentle removal of the calculi etc.

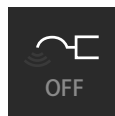

### OFF

The tip does not vibrate.

## ■ Power Adjustment

You can change the power level in each range.

Range	Power Setting Range
PERIO	0-10 NOTE 1
ENDO	0-15 NOTE 1
SCALING	0-25
BOOST	0-25

NOTE 1: When changing the range, if you hold down Up for more than 3 seconds, the power value can be temporarily changed beyond the upper limit, up to a maximum of 25. Press Enter to confirm. Note, however, this value is not memorized and the power value returns to the original value when the power of the dental treatment unit is turned OFF.

### When picked up

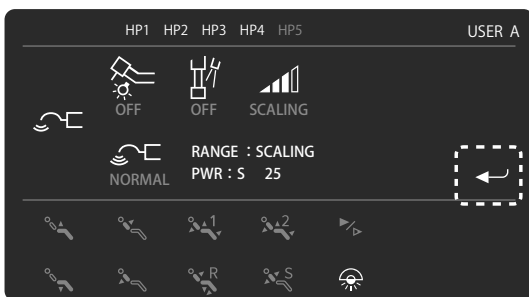

① Press Enter on the pickup screen.

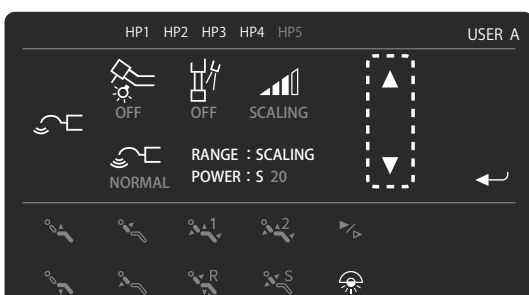

② The power value change screen will appear.

Press the Up/Down arrows to change the power value.  
(When 0 is selected, the scaler does not vibrate)

③ Press Enter to confirm.



## During vibration

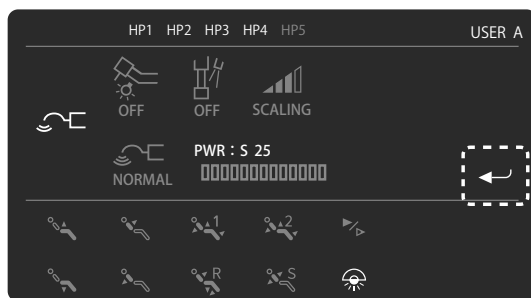

Although you can change the numerical power value during vibration, the power itself will not change.  
The power will change when you step on the foot control pedal again.

① When the power bar is displayed during vibration, press Enter.

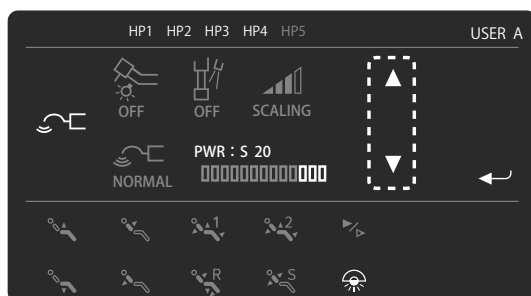

② Press the Up/Down arrows to change the power value.  
(When 0 is selected, the scaler does not vibrate)

③ Press Enter to confirm.

## ■ Various Settings

Various settings and changes can be made.  
For settings, refer to the following sections.

- Switching water flow ON/OFF p. 49
- Switching the light ON/OFF, changing brightness level p. 49
- Scaler one-touch mode p. 102  
(selecting continuous vibration or pedal synchronization)

## 4.7 Unit

<b>⚠ WARNING</b>	
<b>⊘</b>	Do not lean on the unit or apply excessive load. Do not push the housing at the lower part of the unit or touch it while operating the chair.
	● This may cause damage/faults due to unforeseen circumstances.
<b>⊘</b>	Do not open the unit door while operating the seat/backrest.
	● This may cause damage/faults due to unforeseen circumstances.
<b>⚠ CAUTION</b>	
<b>!</b>	Allow sufficient space when opening the unit door.
	Open and close the door within a 90° range. ● If the door is opened by force, damage to the door or its surroundings may occur, or it may cause damage/fault.

### 4.7.1 Part Names

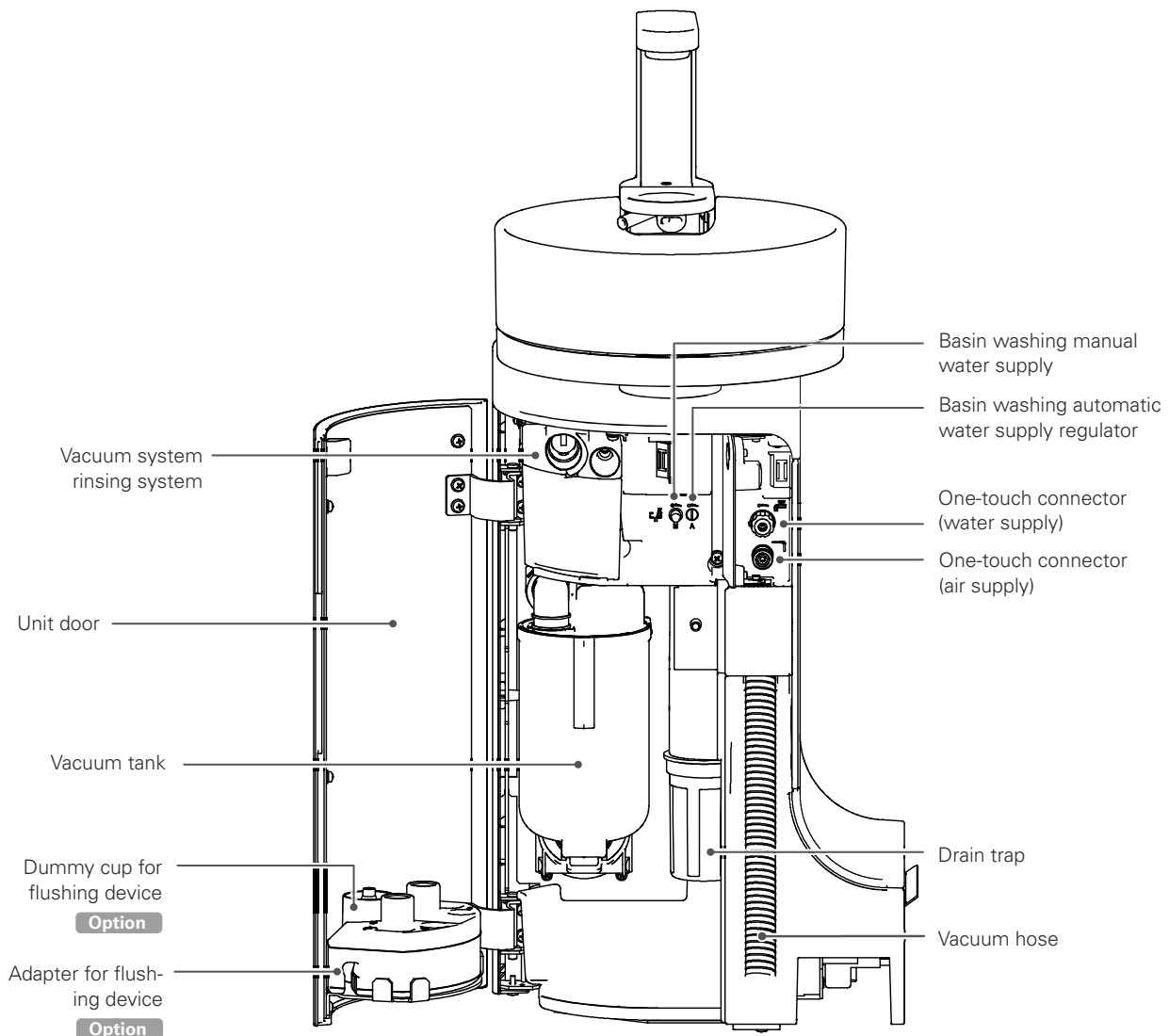

## ■ Opening and Closing the Unit Door

Open the unit door to carry out maintenance.

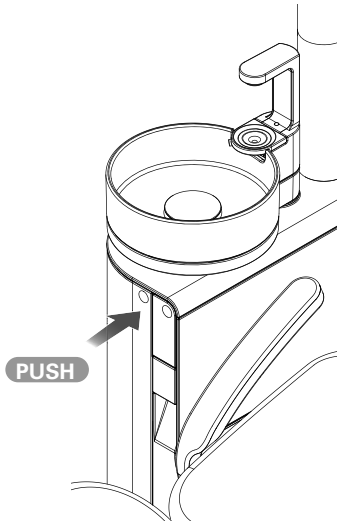

Push circular mark to open the unit door.  
Open the door about 90°.

When closing the unit door, push the circular mark again until you hear a click.

## 4.7.2 Warmer

### CAUTION



When the warmer is ON, always be sure to check the temperature of the hot water before use. If the warmer is not needed, turn the switch OFF.

- Scalding due to high temperature and damage/faults due to overheating may occur.

The water flow to each instrument and the cup water supply temperature from the automatic filler can be set by operating the warmer.

### Warm water temperature setting

Switch or OFF the water temperature of the warmer using the common settings. The water temperature can be set in 3 stages(L, M, H)

 p. 94

- ① Switching the setting to L, M, or H activates the internal heater. It becomes warm water after a certain period of time.  
(The time it takes to become warm water depends on the temperature and water temperature.)
- ② Check the water temperature of the cup water supply and the three-way syringe before use.  
Warm water may vary depending on where it is supplied. Check the temperature enough where warm water is needed.

### 4.7.3 One-touch Connectors (water supply/air supply)

#### ⚠ CAUTION



Be sure to securely connect the one-touch joints (water supply joint/air supply joint) to the one-touch connector (water supply connector/air supply connector).

- An inadequate connection may cause a water leak/air leak/joint disconnection.

The water supply or air can be taken from the unit panel.

To take supply from the one-touch connectors, use a one-touch joint (water supply joint/air supply joint). **Option**

#### ■ Opening and Closing the One-touch Connector Door

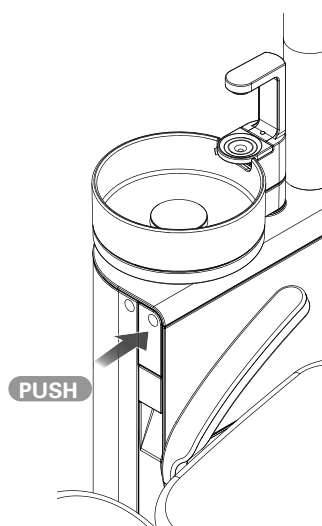

Push the one-touch fitting door circular mark to open the door.  
Open the door about 90°.

When closing the door, push the circular marker again until a click is heard.

#### ■ Water supply connector

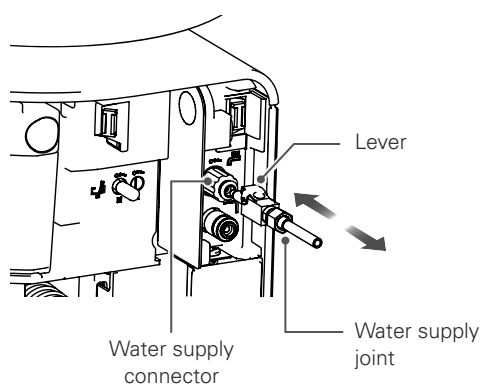

##### Water supply joint connector

Insert the water supply joint into the water supply connector in the panel.  
Push it in until it clicks.

##### Water Supply Joint Removal

Pull the joint while pressing the water supply joint lever.

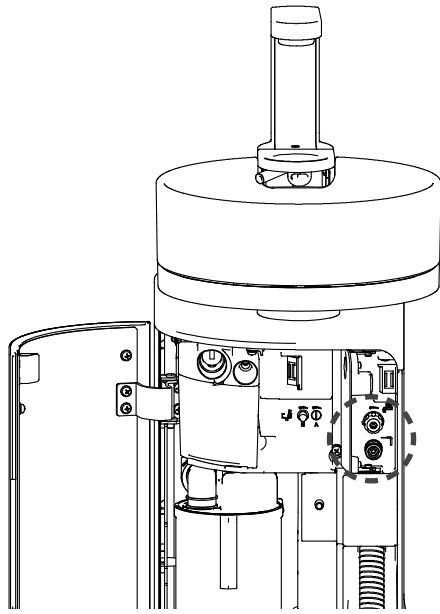

### Water supply rate adjustment

The water supply connectors themselves are the adjustment knobs to control the water supply rate.  
Turn the knob to adjust the water supply rate.

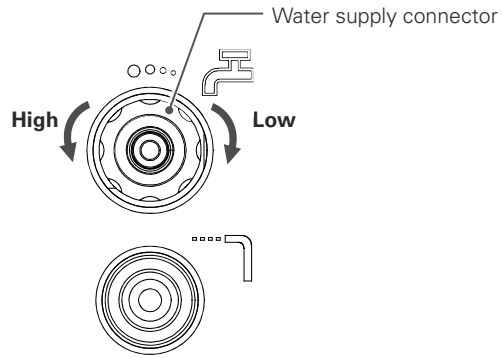

### ■ Air supply connector

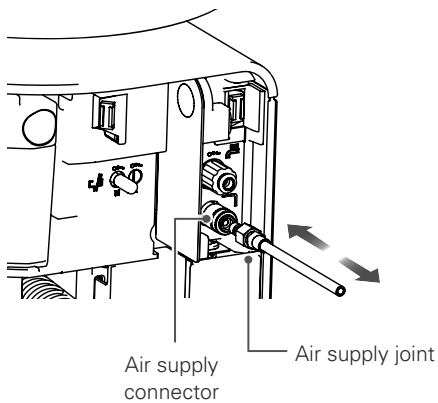

### Air Supply Joint Connection

Insert the air supply joint into the air supply connector on the panel. Push it in until it clicks.

The supply pressure depends on the pressure of the air supplied to the chair unit.

The pressure of the air supply connector cannot be changed.

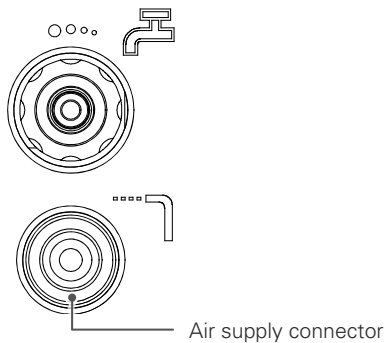

### Air Supply Joint Removal

Slide the outer ring of the air supply joint backward and remove the air supply joint.

Hold the air supply joint firmly when removing it. The air supply joint may fly out quickly due to the air pressure.

The O-ring inside the water supply connector can wear out, so apply Vaseline to the tip of the air supply joint at least once a month.

## 4.8 Basin

### 4.8.1 Basic Operation

<b>⚠ WARNING</b>	
<b>!</b>	<p>Let the basin rotate only when gargling.</p> <p>Avoid dangerous behavior such as the mischievous pranks of children, rough operation, leaning and putting your hands on it, and always check that it is safe.</p> <ul style="list-style-type: none"> <li>● Accidents such as the pinching of fingers and falling may occur.</li> </ul>
<b>⚠ CAUTION</b>	
<b>⊘</b>	<p>Do not subject the basin and surroundings to excessive impacts.</p> <p>Do not strongly scratch the basin surface or the basin unit surface and do not hit it with hard or sharp objects.</p> <ul style="list-style-type: none"> <li>● This may cause damage and injury.</li> </ul>
<b>⊘</b>	<p>Do not expose the basin to strongly colored chemicals over a long period.</p> <p>If chemicals do adhere, flush away with running water immediately and wipe with a sponge or the like.</p> <ul style="list-style-type: none"> <li>● Color may remain.</li> </ul>
<b>⊘</b>	<p>Do not run hot water into the basin.</p> <ul style="list-style-type: none"> <li>● This may cause a fault.</li> </ul>
<b>!</b>	<p>If there are abnormalities such as cracks, chipping, etc. in the basin, stop using it and immediately request a replacement.</p> <ul style="list-style-type: none"> <li>● If use of the unit is continued with an abnormality, accidents or injury may occur.</li> </ul>

### ■ Swiveling the Basin

Move the basin to the gargle position so that gargling is easy.

The movable range is about 80°.

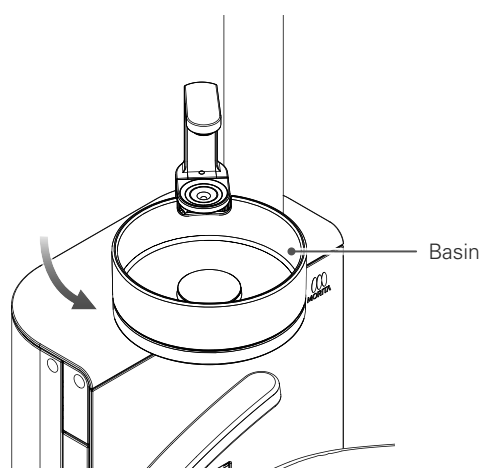

#### Manual Swiveling of the Basin

Swivel the basin manually.

Hold the lower part of the basin and slowly move it.

Return the basin to its original position when chair operation is performed.

When the basin is moving, chair operations other than descent are not possible.

#### Electrically Operated Basin Option

##### ① Automatic Swiveling of the Basin

After the chair moves to the gargle position (soft memory), the basin automatically moves to the gargle position.

##### ② Automatic return of the Basin

If the basin is in the gargle position during automatic operation of the chair, automatic operation of the chair will start after the basin has automatically returned to its original position.

## ■ Automatic Rinsing of the Basin

This operates in conjunction with the cup water supply, with water being supplied automatically to the basin for rinsing. After supplying water to the cup, water is supplied to the basin and will stop after a certain time.

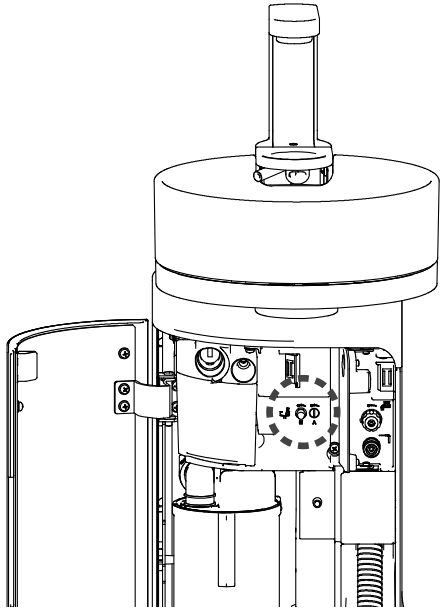

### Setting the flow rate of the water for automatic rinsing

The flow rate of the water for automatic rinsing can be set. Turn the automatic rinsing water supply valve on the unit panel with a flat-head screwdriver to adjust the flow.

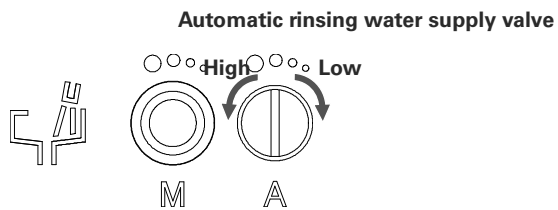

## ■ Basin Manual Water Supply

If the bowl becomes dirty and if water is continually supplied, supply water to the basin manually as necessary. The supply rate can be adjusted with manual water supply valve.

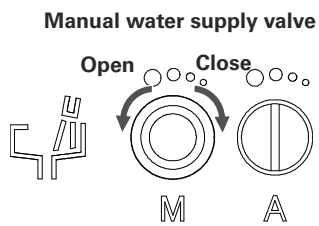



## 4.8.2 Cup Water Supply

### ⚠ WARNING

⊘	Do not subject the water supply device to excessive loads or impacts, such as by grasping the automatic filler. Do not subject the device to excessive loads, forcibly disassemble it, or pour water over it.
	● This may cause damage/water leak/faults.
!	Do not use the water supply device with the bowl washing nozzle removed.
	● The water for bowl washing will spout upward.
!	If the sensor is dirty, wipe it with a dry cloth etc.
	● The automatic filler may not work properly.

### ■ Automatic water supply

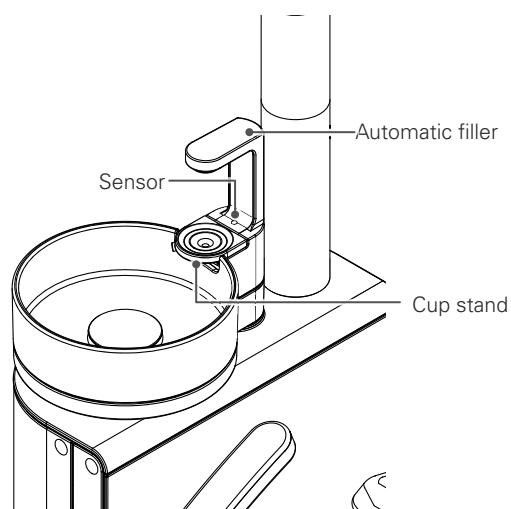

#### Operation

When a cup (made of paper or metal) is placed on the cup stand, a sensor senses the cup and water is automatically supplied.

The water level in the cup is detected and water is supplied to the set position.

If a cup filled to the set position is again placed on the cup stand, water will be supplied momentarily. This does not indicate a fault abnormal.

Materials that transmit light such as transparent glass cups and semi-transparent plastic cups cannot be used because the sensor does not react correctly.

To prevent malfunctions, there is a time difference of about 0.5 seconds from between sensing of the cup by the sensor and supply of water. Place the cup gently.

### ■ Manual water supply





Water flows while the cup water supply switch is pressed (assistant-side operation panel).

Be sure to put the cup in position before operating the switch. If the cup is not in position, water will be spilled.

## 4.9 Operating Light

For details on how to use the operating light, be sure to refer to the separate operation instructions.

 <b>WARNING</b>	
	<p>Be careful that the light arm does not hit the patient or surroundings during lighting operations or when the chair moves.</p> <ul style="list-style-type: none"> <li>● This could result in accident or injury.</li> </ul>
	<p>Do not subject the light (head, arm etc.) to excessive impacts or vibration.</p> <p>Do not let moisture adhere to the light. If the light gets wet, turn the main switch on the main unit OFF and wipe the light with a dry cloth etc. In this case, do not use the light until it is dry enough.</p> <ul style="list-style-type: none"> <li>● Accidents such as injury and damage/faults may occur.</li> </ul>

### 4.9.1 Basic Operation

#### ■ ON/OFF Operation



##### Operation

Press the operating light ON/OFF icon on the display panel or the same switch on the assistant-side operation panel to switch the light on or off.

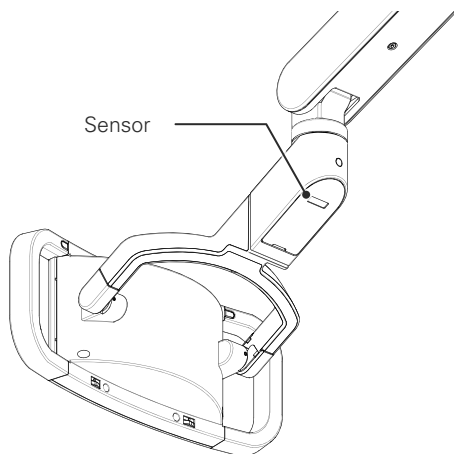

##### Touchless Sensor Option

When a hand is held over the sensor, the light turns ON/OFF.  
(The sensing distance of the sensor is about 100mm in the direction of the sensor)

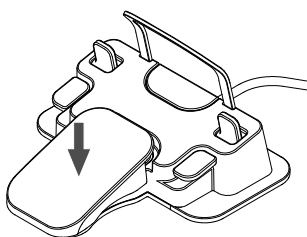

##### ON/OFF using the Foot Control

The light can be switched ON/OFF by stepping on the foot pedal (over 2 seconds) while the doctor-side instruments (excluding the threeway syringe) are in the holders.

The light goes ON/OFF each time the foot pedal is stepped on.

## ■ Range Selection

Select a range. You can switch between ranges.

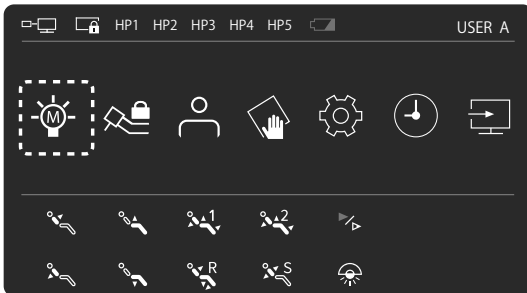

① Press the operating light settings icon.

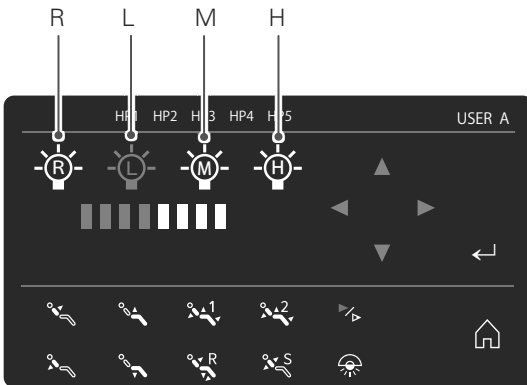

The range switching screen will appear.

Press the range icons to switch between the ranges (R, L, M, H).

The corresponding brightness levels are displayed.

## 4.9.2 Setting

### ■ Adjusting Illumination in Each Range

The illumination in each range can be adjusted (excluding the R range).  
 (Maximum illumination: 30,000 Lx [at H range maximum adjustment])  
 Refer to various settings in "Operating Light Illumination Setting" for the adjustment method.

☞ p. 89

### ■ Link settings

#### Automatic operation link settings

Turn ON/OFF the operating light together with chair automatic operation (AUTO1, AUTO2, R (reset), S (soft memory)).  
 The factory settings are as follows. Change the settings as necessary.

☞ pp. 98-99

Automatic Operation	Light
AUTO1/AUTO2	ON
Reset	OFF
Soft memory (gargle position movement)	OFF
Soft memory (return)	ON

#### Instrument Link Settings

The operating light turns ON/OFF in conjunction with picking up an instrument.

☞ p. 100

## 4.10 Other Settings

Use the icons on the home screen to perform settings and operations.

### 4.10.1 Countdown Timer

A digital countdown timer is provided.

#### ■ Setting the Time on the Timer

Up to 6 patterns can be set on the timer.



① Press the countdown timer icon on the home screen.

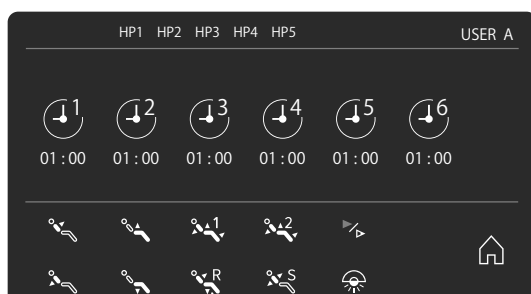

② The panel display displays the countdown timer selection display. Press any of the No. 1 to No. 6 countdown timer icons on the home screen, and perform settings. To set the time on the next countdown timer, press the home icon and then perform the setting from the home screen in the same way.

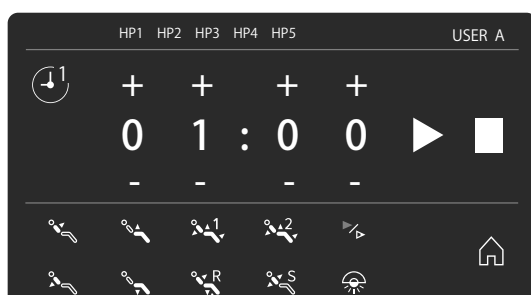

③ The countdown time settings screen appears. Set the time using the + and- symbols. (Minutes: 1 minute unit, seconds: 1 second unit) The maximum time setting is 59 minutes 59 seconds.

## Starting Countdown



③ Press  to start the countdown and return to the home screen.

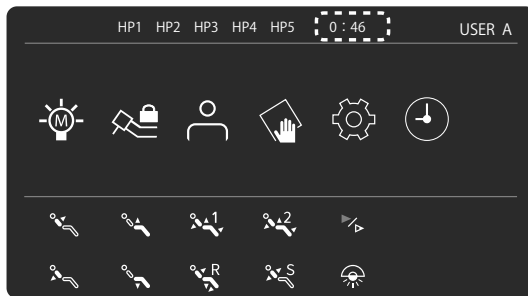

④ During countdown, the time remaining is displayed at the top of the home screen.

When the time reaches zero, an alarm sounds.

The alarm sounds for about 15 seconds then stops.

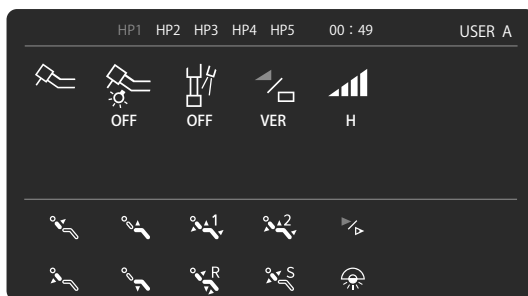

Note that if an instrument is picked up during countdown, the display switches to the pickup screen but the countdown continues.

The time remaining is displayed at the top of the screen.

## ■ Interrupting the Countdown

### When instrument is in holder



① Display operation

Press the countdown timer icon.

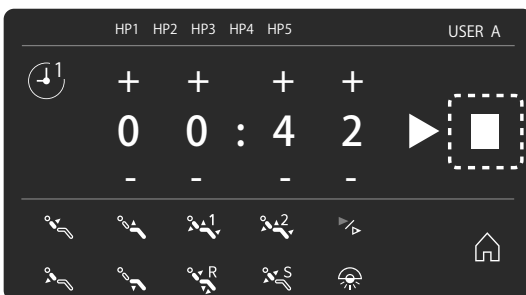

The countdown time display screen appears.

Press  to stop the countdown. The time will be reset.

### After picking up instrument

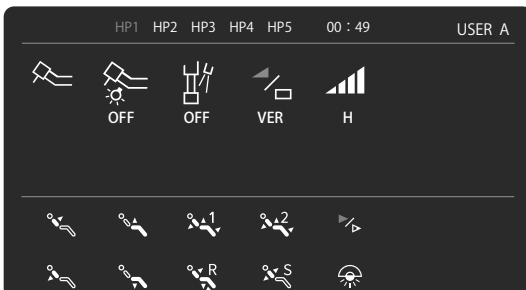

Return the instrument to the holder.

On the home screen, press the countdown timer icon to display the countdown time display screen.

Press  to stop the countdown. The time will be reset and the display will return to the home screen.

## ■ Stopping the alarm

### When instrument is in holder



- Display panel operation  
Press the countdown timer icon.



The countdown time display screen appears.  
Press  to stop the alarm. The display will return to the home screen.

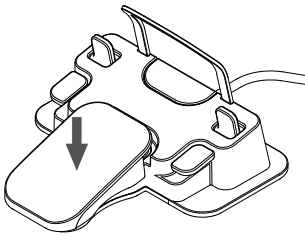

- Foot control operation  
Step on the pedal of the foot control to stop the alarm.  
Note that when the pedal operation is set to operate the operating light, pressing on the pedal for 2 seconds or more will switch ON the operating light.

### After picking up instrument



Return the instrument to the holder.  
On the home screen, press the countdown timer icon to display the countdown time display screen.  
Press  to stop the alarm. The display will return to the home screen.



## 4.10.2 Display while Instruments are in Holders

You can perform various settings and operations when the instruments are in the holders.

### ■ Switching Operator Number

A maximum of 5 patterns can be registered, each including instrument settings and/or user settings.

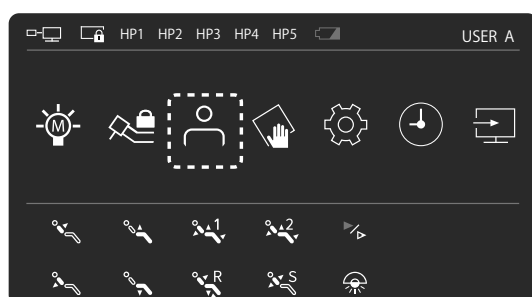

① Press the select operator icon on the home screen.

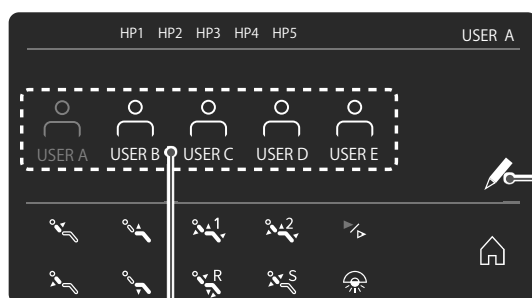

Operator icons

Pen symbol

② The operator selection screen appears.

The currently selected operator icon is displayed in blue.

Press the operator icon you wish to switch to.

The selected operator icon turns blue, and this operator is now selected.

Following selection, the display will return to the home screen.



③ If necessary, you can register and display the name of each operator.

Press the pen symbol on the operator selection screen to enter the name.

Use the letters (upper case only), full stops (.), space ( ) and backspace (←) to enter a name. Press Enter (↵) to register the name. Then the display returns to the operator display screen.

If you press x before pressing Enter, the name you have entered will not be registered.

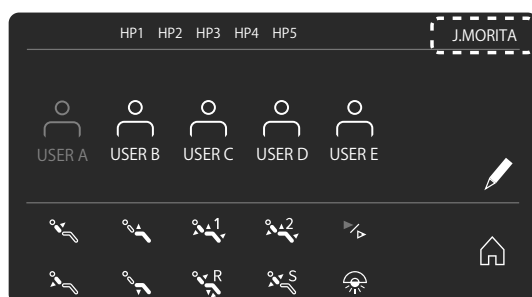

④ The registered name is displayed at the top right of the operator display screen.

## Instrument Lock

Pauses a specific doctor-side instrument circuit (HP) temporarily.

Used when an instrument is removed etc.

Locked circuits are in an unusable state and will not respond to a pickup.

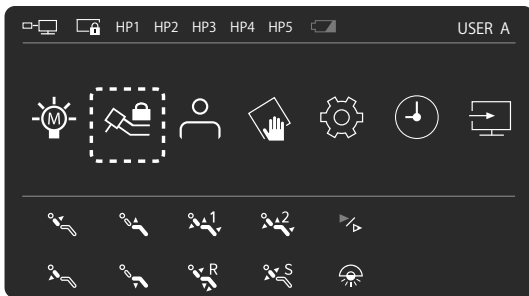

① Press the instrument lock icon.



② Go to the selection screen.

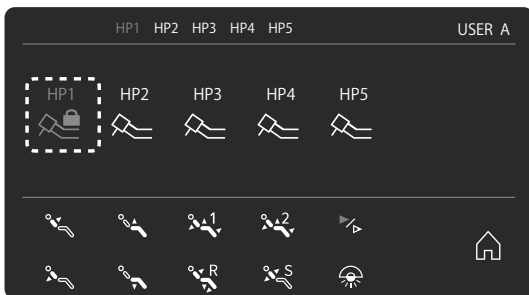

③ Press the handpiece circuit icon for the handpiece you wish to lock. The icon changes to an icon with a lock symbol and turns blue.

Example: When HP1 circuit is locked

To release the lock, press the icon of the locked handpiece circuit. The lock is released and the icon returns to its original form.

## ■ Operating light brightness setting

You can select the range (R, L, M, H) and set the brightness within each range (except R).  
Note that you also change the brightness level while the operating light is ON.

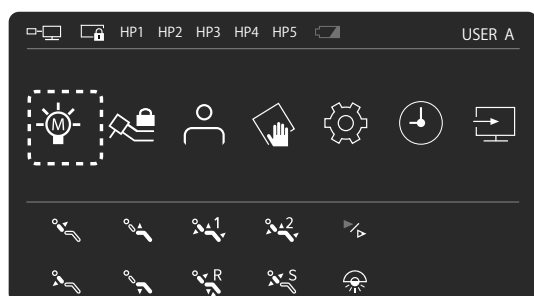

① Press the operating light icon on the home screen.

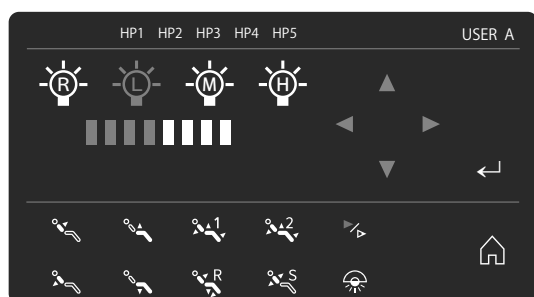

② The operating light control screen appears.  
The currently selected range and brightness level are displayed in blue.

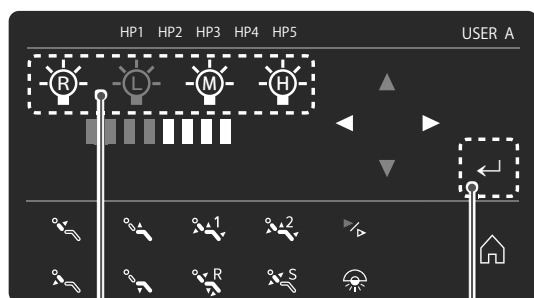

③ To change the brightness level of each range, press the range icon for the range you wish to change to display the range screen and press Enter enable changes in the brightness level. Increase/decrease the level using the Left/Right arrows.

④ After making the change, press Enter to confirm.  
Note that each range has an upper limit and settings beyond the upper limit cannot be made.

Range	Variable level setting
R	1 (cannot be changed)
L	1-4
M	1-6
H	1-8

### 4.10.3 Show Display in PC Monitor

The screen of the system display panel can be displayed on the liquid crystal display.

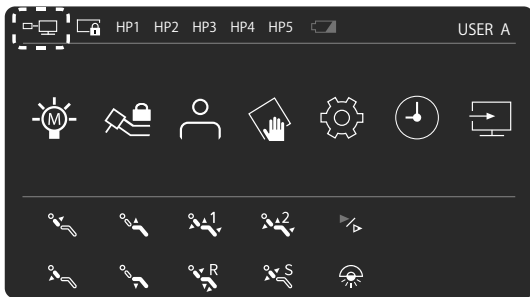
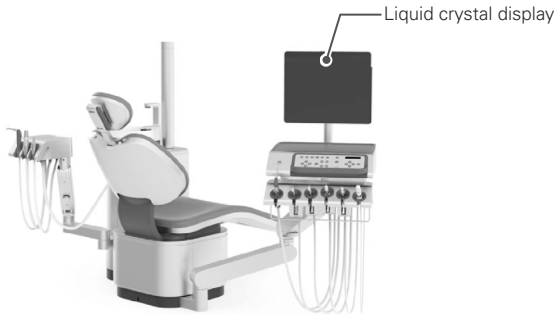

Press the icon on the home screen.  
When you press the icon, the screen of the system display panel appears on the liquid crystal display.  
Press the icon to switch as shown below.

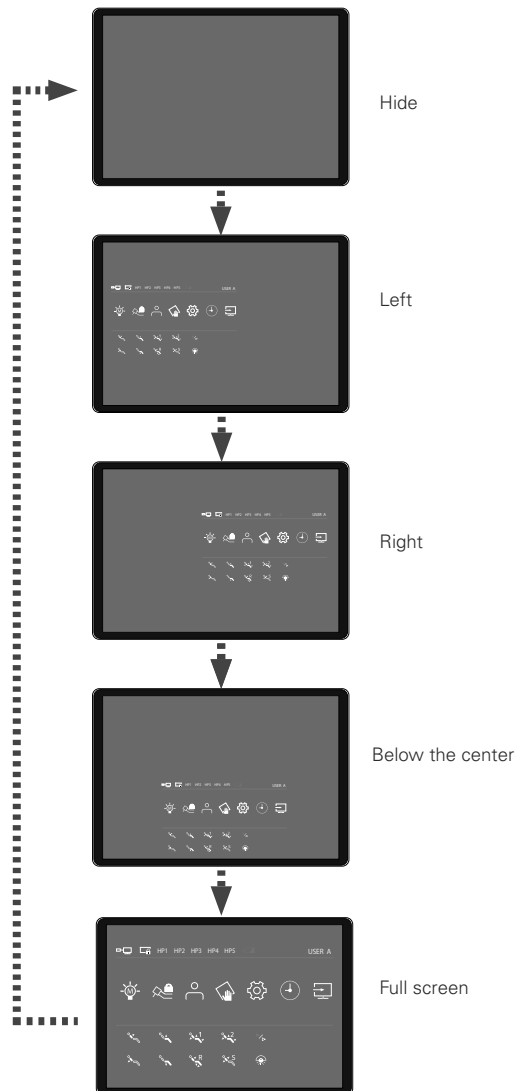

## Common Settings

Make settings common to all operators.

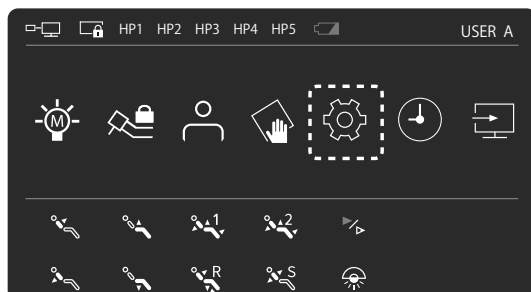

① Press the settings icon on the home screen.

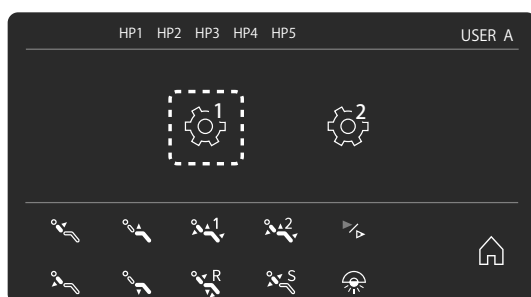

② The common settings and individual user settings control screen appears.  
Press the common settings (settings 1) icon to display settings screens various items.  
From this point, refer to "4.10.4 Common Settings" to make desired settings.

## Individual User Settings

Make separate settings for individual operators.

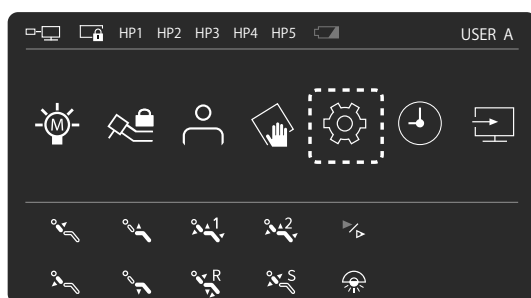

① Press the settings icon on the home screen.



② The common settings and individual user settings control screen appears.  
Press the individual user settings (settings 2) icon to display settings screens for various items.  
From this point, refer to "4.10.5 Individual User Settings" to make desired settings.

## 4.10.4 Common Settings

Make settings common to all operators.

Make settings according to the following procedure. The instruments must be in their holders.



① Press the settings icon on the home screen.

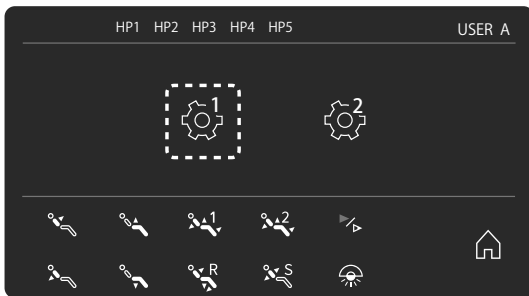

② The common settings and individual user settings control screen appears.  
Press the common settings (settings 1) icon.

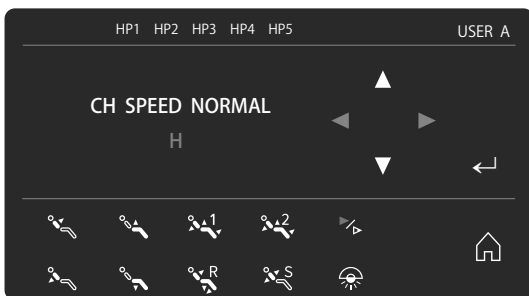

③ Press the Up/Down arrows to toggle between settings screens for various items.  
Making settings on the settings screens for items you wish to set.

Example: Selecting chair speed.



④ After completing the settings, use the Up/Down arrows to go to the RETURN MAIN MENU screen and press Enter or the home screen icon to return to the home screen.  
Please note that if you press the home screen icon before pressing Enter, the new setting will not be applied.

Enter  
Home screen icon

## Chair speed switching

Chair speed switching offers two basic chair speeds NORMAL (standard) and SLOW. Within each of the NORMAL and SLOW options, you can make further adjustments to the CH SPEED setting.

### NORMAL (standard) settings

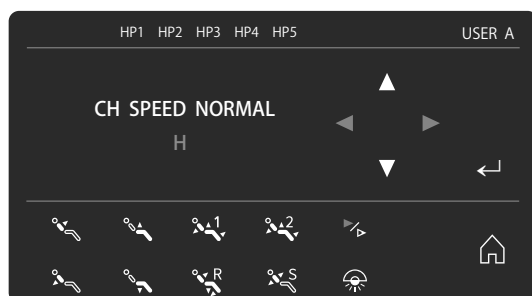

- ① Go to CH SPEED NORMAL settings screen.  
Press Enter.

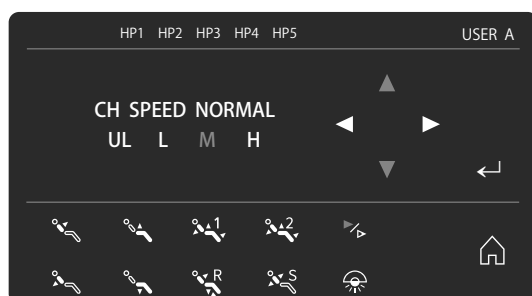

- ② The speed settings screen will appear.  
The current setting blinks blue.  
Select CH SPEED (UL, L, M or H) using the Left/Right arrows and press Enter to confirm.

### SLOW settings

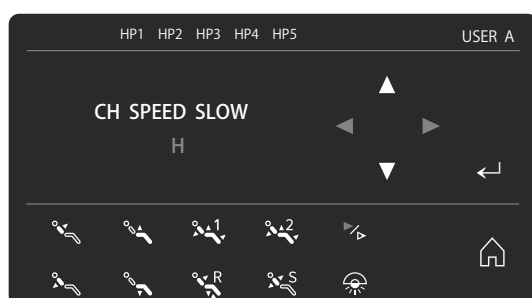

- ① Go to the CH SPEED SLOW settings screen.  
Press Enter.



- ② The speed settings screen will appear.  
The current setting blinks blue.  
Select CH SPEED (UL, L, M or H) using the Left/Right arrows and press Enter to confirm.

## ■ Automatic power OFF

When the main unit has not been used for a certain period of time, the power supply turns OFF automatically for safety (the factory setting is 120 minutes).

The following condition arises in during power save.

- the operating light goes off
- the display goes off
- chair operation input is not possible
- the water supply stops (the water supply solenoid valve closes)

Power save mode is canceled by one of the following operations.

- pressing the automatic operation icon on the display panel or pressing the automatic operation switch on the assistant-side operation panel
- stepping on the foot pedal
- picking up a doctor-side instrument

The time until power save (60 or 120 minutes) and OFF (continuous electricity supply) can be selected.

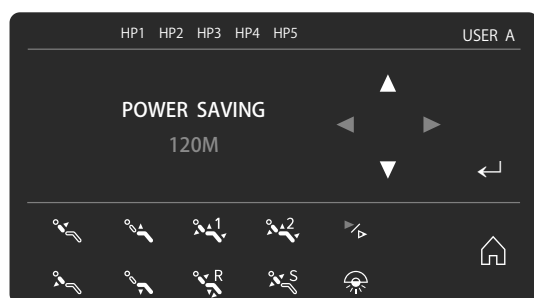

- ① Go to the power save settings screen.  
Press Enter.

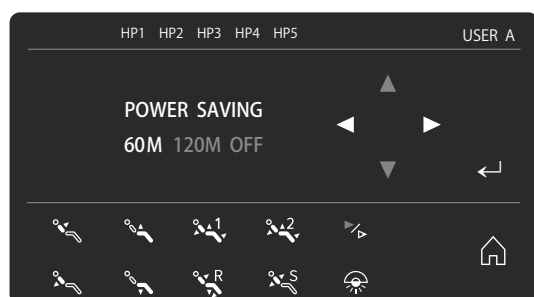

- ② The power save time settings screen will appear.  
The time blinks blue.  
Press the Left/Right arrows to change the power save time, or select NONE.  
Press Enter to confirm.



## ■ Cup Water Volume

Set the volume of water to be supplied to the cup.

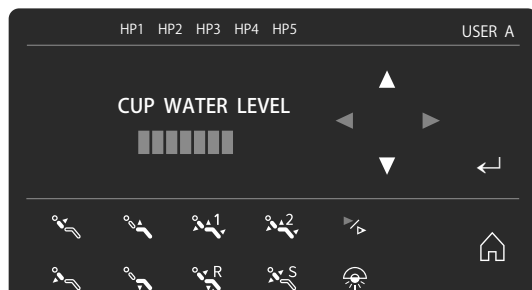

- ① Go to the settings screen for cup water volume. Press Enter.

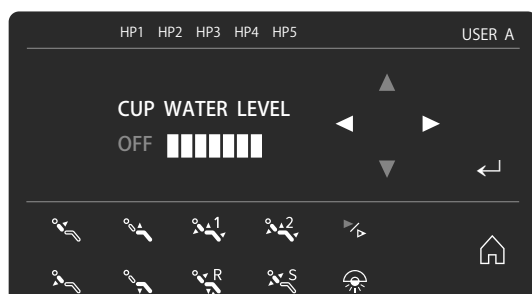

- ② The screen for changing the water volume will appear. The water level blinks blue. Press the Left/Right arrows to change the water volume or switch the supply OFF. Press Enter to confirm.

## ■ Warm water temperature setting

Set the water temperature of the wamer or OFF.

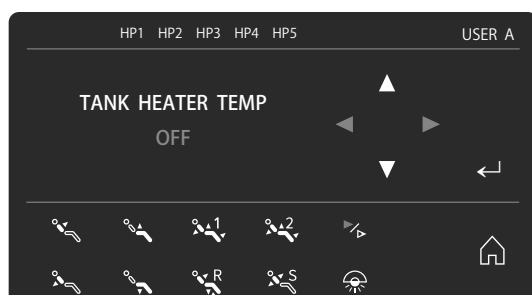

[Factory setting : OFF]

- ① Display the wamer water temperature setting screen. Press the Enter key.

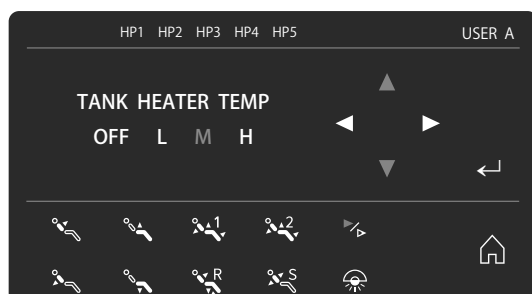

- ② The warmer water temperature change screen is displayed. The current setting blinks blue. Select the water temperature (L, M, H) or OFF using the Left/Right marks and press the Enter mark.

## Vacuum System Rinsing Settings

When rinsing the vacuum circuit, it is necessary to select whether to rinse with water or cleanser.



- ① Go to the settings screen for vacuum system cleaning. Press Enter.



- ② The settings screen for vacuum system cleaning will appear. The current setting blinks blue. Press the Left/Right arrows to select water or cleanser. Press Enter to confirm.

## Foot control link settings

You can allocate operations to the foot control pedal.

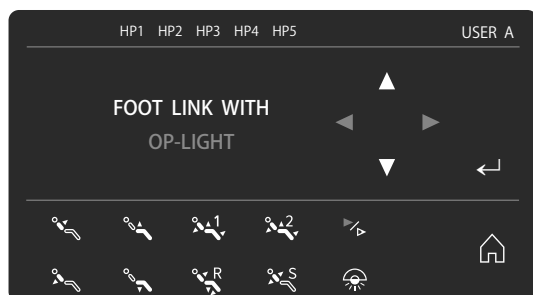

- ① Go to the settings screen for foot control link operations. Press Enter.

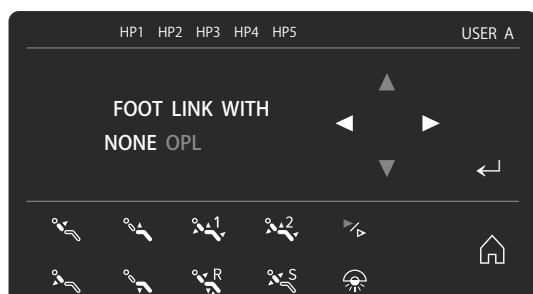

- ② The screen for changing foot control link operations will appear. The current setting blinks blue. Select using the Left/Right arrows.  
 NONE : Chair operations not allocated to pedal.  
 OP LIGHT : Step on the pedal for 2 seconds or more while the instruments are in their holders to turn on the operating light. Press the pedal again for 2 seconds or more to turn the light OFF.

Press Enter to confirm.

## 4.10.5 Individual User Settings

Makes common settings.

Make settings according to the following procedure. The instruments must be in their holders.

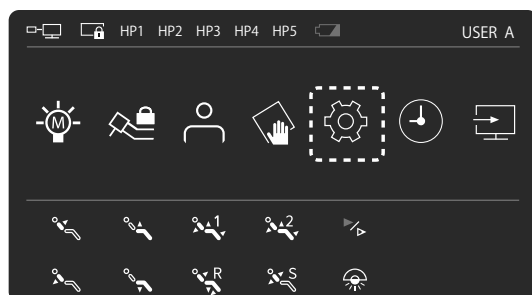

① Press the settings icon on the home screen.



② The common settings and individual user settings control screen appears.  
Press the individual user settings (settings 2) icon.

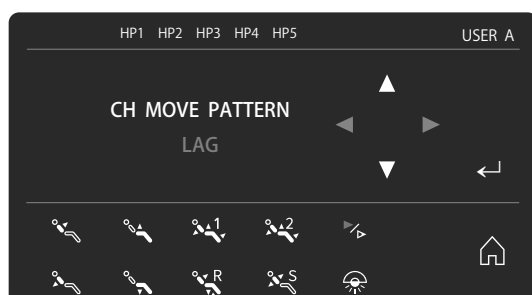

③ Press the Up/Down arrows to toggle between settings screens for various items.  
Making settings on the settings screens for items you wish to set.

Example: Selecting a CH AUTO PATTERN



Enter

Home screen icon

④ After completing the settings, use the Up/Down arrows to go to the RETURN MAIN MENU screen and press Enter or the home screen icon to return to the home screen.

## ■ Chair Auto Pattern

Three types of operation timing can be selected at the time of automatic operation.

- SIMUL (seat moves up and backrest goes back simultaneously)  
 Seat and backrest move simultaneously.  
 Although the operation time is shortened, the patient will experience more movement at the beginning.
- DELAY (automatically delayed)  
 Seat starts to move up → backrest starts to go back about 1 second later. Reduces initial movement experienced by patient (recommended)
- INDP (automatic and independent)  
 Seat finishes moving up → backrest starts going down. The patient will experience less movement at the beginning, but the operation time will take longer.



- ① Go to the chair auto pattern settings screen.  
 Press Enter.



- ② The screen for changing the chair auto pattern will appear.  
 The current setting blinks blue.  
 Select the operation timing (SIMUL, DELAY, INDP) using the Left/Right arrows and press Enter to make the setting.

## ■ Linking the Operating Light to Chair Auto Operation

You can link automatic light switching to the chair automatic operations.

ON: Light comes on after completion of the chair AUTO1, AUTO2, or after movement to the gargle position is completed. Also, the light goes off before reset operation starts.

OFF: Lighting is not linked to chair automatic operations

### Linking to AUTO1

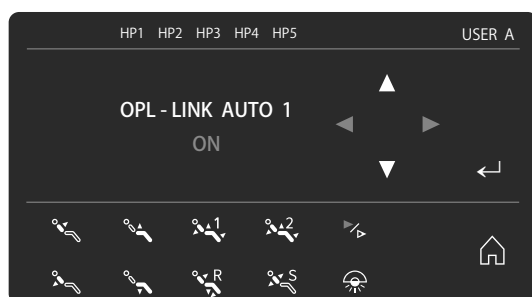

- ① Go to the LIGHT AUTO2 LINK settings screen.  
Press Enter.

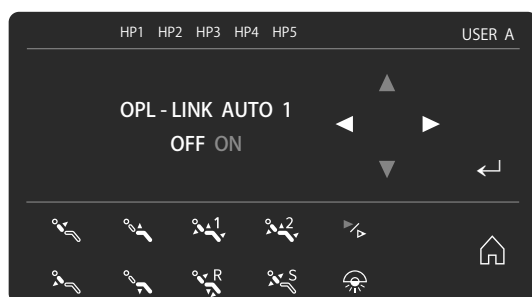

- ② The screen for changing the LIGHT AUTO2 LINK setting will be displayed.  
The current setting blinks blue.  
Select using the Left/Right arrows.  
Press Enter to confirm.

### Linking to AUTO2

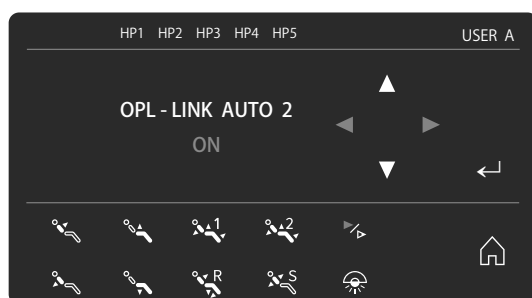

- ① Go to the LIGHT AUTO1 LINK settings screen.  
Press Enter.

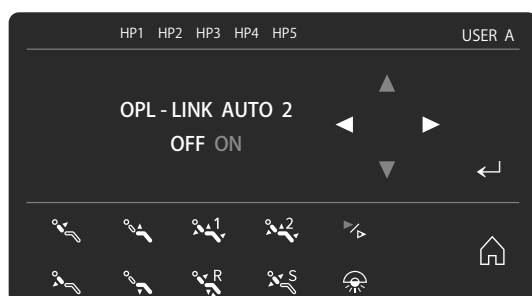

- ② The screen for changing the LIGHT AUTO1 LINK setting will be displayed.  
The current setting blinks blue.  
Select using the Left/Right arrows.  
Press Enter to confirm.

### Linking to soft memory (movement to the gargle position)



- ① Go to the LIGHT AUTOS (soft memory) LINK settings screen.  
Press Enter.



- ② The screen for changing the LIGHT AUTOS LINK setting will be displayed.  
The current setting blinks blue.  
Select using the Left/Right arrows.  
Press Enter to confirm.

### Linking to reset

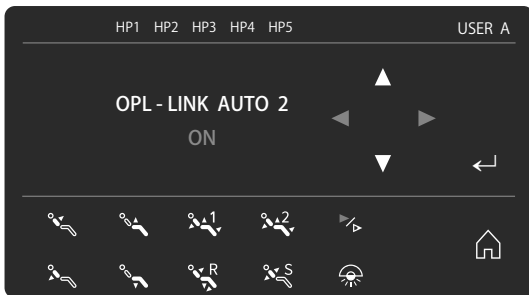

- ① Go to the LIGHT AUTOS (reset) LINK settings screen.  
Press Enter.

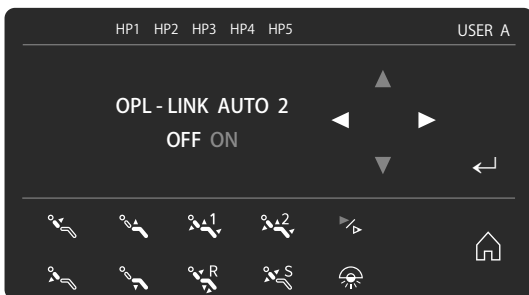

- ② The screen for changing the LIGHT AUTOS LINK setting will be displayed.  
The current setting blinks blue.  
Select using the Left/Right arrows.  
Press Enter to confirm.

## ■ Linking Operating Light to Instruments

You can choose to link (ON) or to not link (OFF) automatic switching of the light to instrument pickup.

ON: When an instrument is picked up, the light comes on.

OFF: No link between picking up an instrument and operation of light.

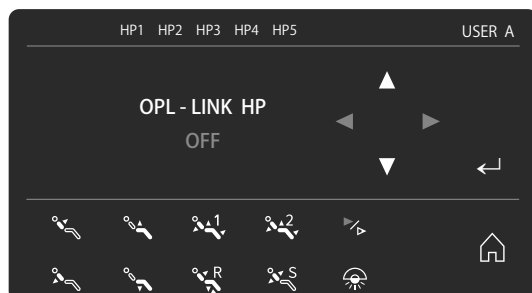

- ① Go to the LIGHT HP (handpiece) LINK settings screen. Press Enter.

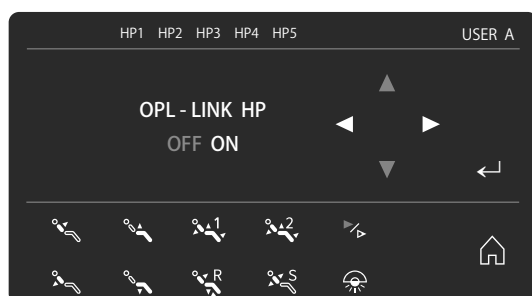

- ② The screen for changing the LIGHT HP LINK setting will be displayed. The current setting blinks blue. Select using the Left/Right arrows. Press Enter to confirm.

## ■ Operating Light Brightness Adjustment Direction

You can select the brightness adjustment direction of the operating light.

BRIGHTEN: Gets brighter with each press.

DIM: Gets dimmer with each press.

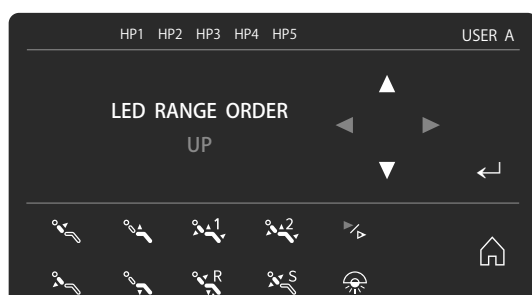

- ① Go to the LIGHT ADJUST DIR settings screen. Press Enter.



- ② The screen for changing the LIGHT ADJUST DIR will appear. The current setting blinks blue. Select using the Left/Right arrows. Press Enter to confirm.

## Countdown timer completion sound

You can select from 4 countdown timer completion sounds.

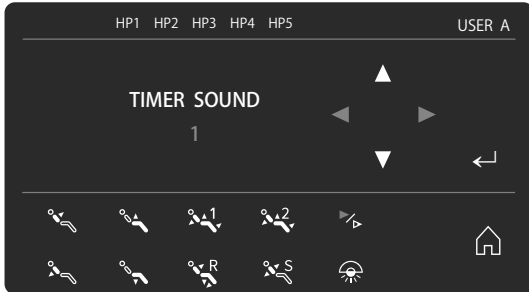

- ① Go to the countdown TIMER SOUND settings screen.  
Press Enter.

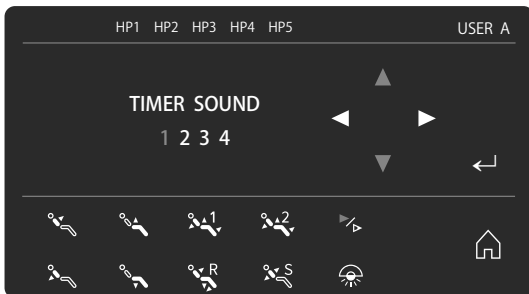

- ② The screen for changing the TIMER SOUND will displayed.  
The current setting blinks blue.  
Select using the Left/Right arrows.  
Press Enter to confirm.

## Buzzer volume

You can select the buzzer volume.

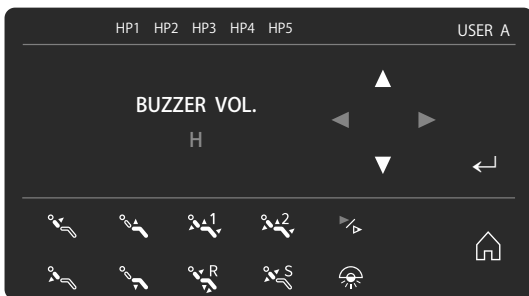

- ① Display the BUZZER VOLUME settings screen.  
Press Enter.

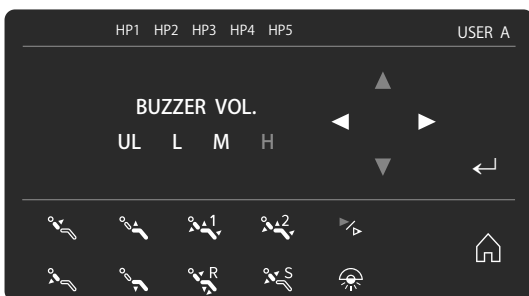

- ② The screen for changing the BUZZER VOLUME will appear.  
The current setting blinks blue.  
Press the Left/Right arrows to select between 4 levels (UL, L, M, H) of BUZZER VOLUME.  
Press Enter to confirm.



## ■ Setting Scaler One-touch Mode

Switches the ultrasonic scaler one-touch mode ON/OFF (applies to specifications including a scaler).

ON: Stepping on the foot control pedal starts continuous vibration. Stepping on the pedal again stops the vibration.

OFF: Scaler only vibrates while you are pressing on the foot control pedal.



- ① Go to the SC 1-TOUCH MODE (ultrasonic scaler one-touch mode) settings screen.  
Press Enter.



- ② The screen for changing the SC 1-TOUCH MODE (ultrasonic scaler one-touch mode) will be displayed.  
The current setting blinks blue.  
Select using the Left/Right arrows.  
Press Enter to confirm.

## ■ Micromotor Speed Up/Speed Reduction Ratio Setting

When connecting a speed reduction attachment to the micromotor, set the attachment speed up ratio to display the rotation speed of the attachment.

- Speed up ratio 1:1.0-1:5.9 (change possible in 0.1 units)
- Speed reduction ratio 1.0:1-1024:1 (change possible in 0.1 units)

However, the number of rotations displayed is an “estimate” calculated using the speed up ratio set for the micromotor rotation speed, and may not match the actual speed of rotation. Use this after sufficiently checking the attachment specification etc.

### Speed Up Ratio Setting

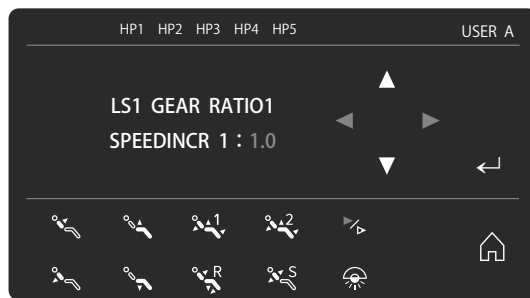

- ① Go to the micromotor speed up ratio settings screen.  
Press Enter.

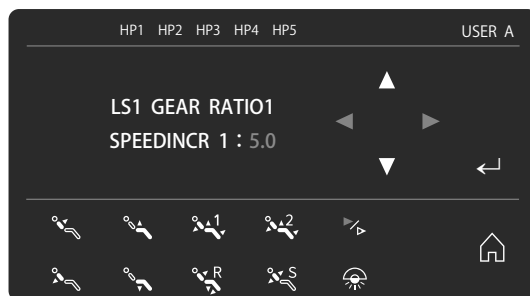

- ② The screen for changing the speed up ratio of the micromotor will be displayed.  
The current setting blinks blue.  
Select using the Up/Down arrows.  
Press Enter to confirm.

### Speed Reduction Ratio Setting

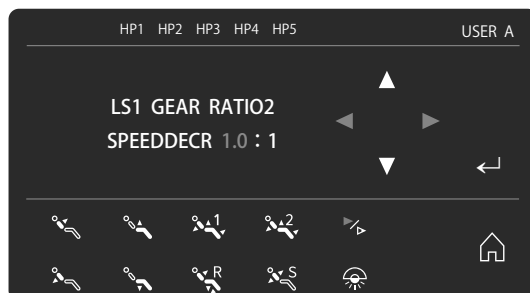

- ① Go to the micromotor speed reduction ratio settings screen.  
Press Enter.

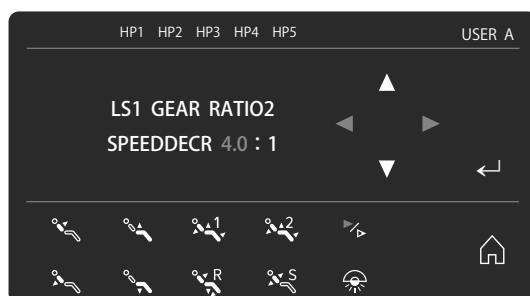

- ② The screen for changing the micromotor speed reduction ratio will be displayed.  
The current setting blinks blue.  
Select using the Up/Down arrows.  
Press Enter to confirm.

## Water Injection Timing (Variable Speed) Setting

When variable speed of the instrument is selected, the following 2 water injection timings can be selected.

This can be set separately for the micromotor (LS) and air turbine (HS).

- INSTANT : Water is injected as soon as you step on the foot control pedal
- DELAY : Water is injected when you press the foot control pedal all the way down.

Settings for each circuit cannot be made if the unit is equipped with multiple circuits of each type, such as 2 air turbine circuits or 2 micromotor circuits.

### Micromotor system (LS) Setting

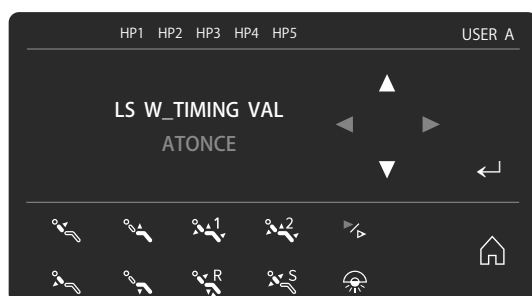

- ① Go to the LSWTIMING VER (micromotor (LS) water injection timing, variable speed) settings screen. Press Enter.

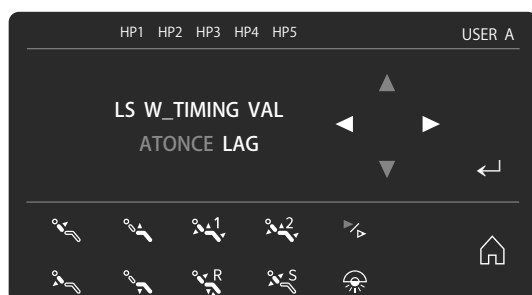

- ② The screen for changing LSWTIMING VER will be displayed. The current setting blinks blue. Select using the Left/Right arrows. Press Enter to confirm.

### Air Turbine System (HS) Setting

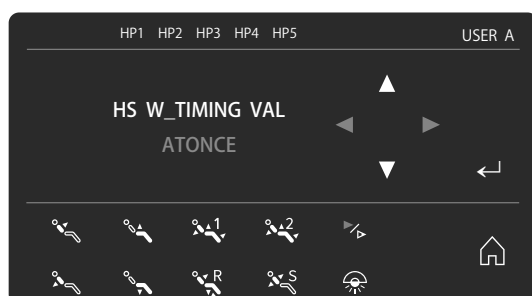

- ① Go to the HSWTIMING VER (air turbine (HS) water injection timing, variable speed) settings screen. Press Enter.

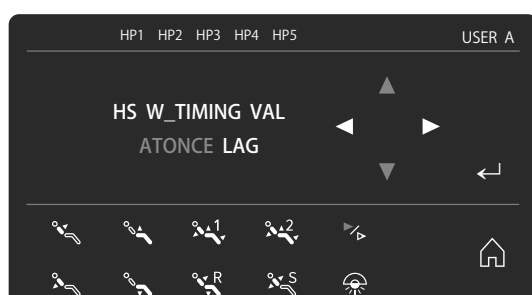

- ② The screen for changing HSWTIMING VER will be displayed. The current setting blinks blue. Select using the Left/Right arrows. Press Enter to confirm.

## Water Injection Timing (Constant Speed) Setting

When constant speed is selected for the instrument, the following 2 water injection timings can be selected. This can be set separately for the micromotor (LS) and air turbine (HS).

- INSTANT : Water is injected as soon as you step on the foot control pedal
- DELAY : Water is injected when you press the foot control pedal all the way down.

Settings for each circuit cannot be made if the unit is equipped with multiple circuits of each type, such as 2 air turbine circuits or 2 micromotor circuits.

### Micromotor system (LS) Setting

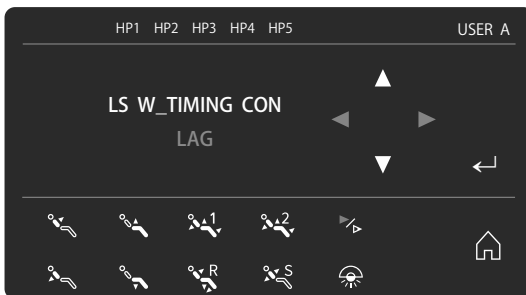

- ① Go to the LSWTIMING FIXED (micromotor (LS) water injection timing, constant speed) settings screen. Press Enter.

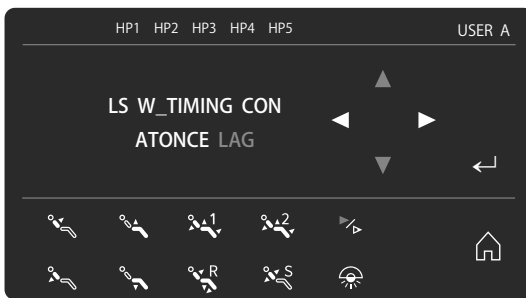

- ② The water injection timing (constant speed) settings screen will appear. The current setting blinks blue. Select using the Left/Right arrows. Press Enter to confirm.

### Air Turbine System (HS) Setting

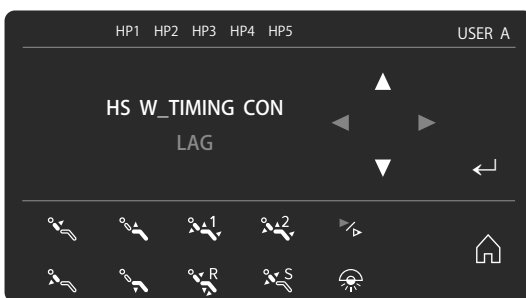

- ① Go to the HSWTIMING FIXED (air turbine (HS) water injection timing, constant speed) settings screen. Press Enter.

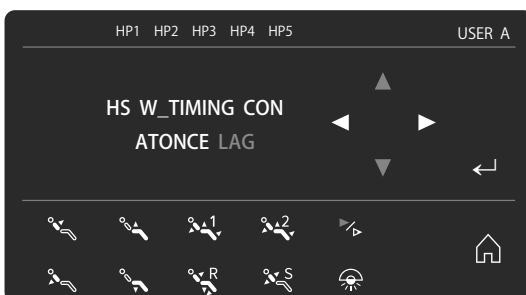

- ② The HSWTIMING FIXED settings screen will be displayed. The current setting blinks blue. Select using the Left/Right arrows. Press Enter to confirm.

## ■ AI Catch Setting

You can set AI catch ON/OFF, the timing at which to catch the tube, and the timing delay period for release of the tube.

### AI Catch ON/OFF Setting

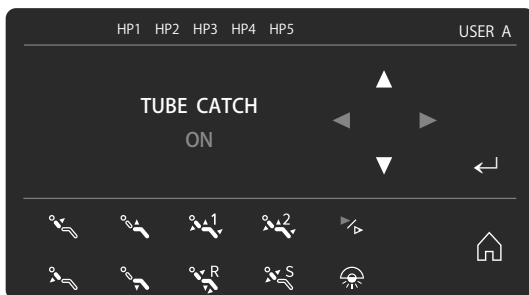

- ① Go to the TUBE CATCH OP ON/OFF (AI catch ON/OFF) settings screen. Press Enter.

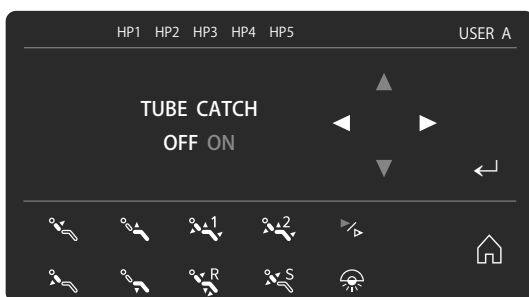

- ② The screen for changing the TUBE CATCH OP ON/OFF setting will be displayed. The current setting blinks blue. Select using the Left/Right arrows. Press Enter to confirm.

### AI Catch/Timing Delay Period Setting

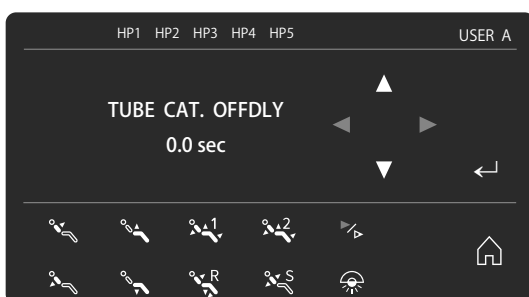

- ① Go to the CATCH OFF DELAY (AI catch OFF delay period) settings screen. Press Enter.

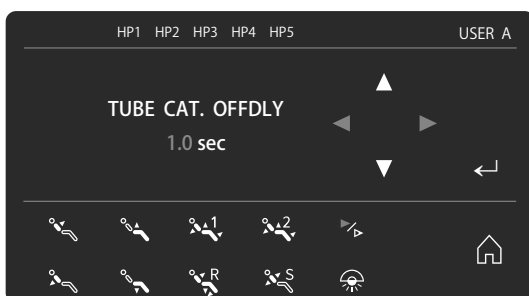

- ② The screen for changing the CATCH OFF DELAY will be displayed. The current setting blinks blue. Set the delay period using the Up/Down arrows. Press Enter to confirm.

### AI Catch/Release Delay Period Setting

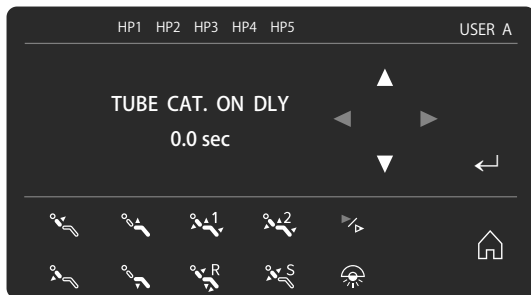

- ① Go to the CATCH ON DELAY (AI catch ON delay period) settings screen.  
Press Enter.

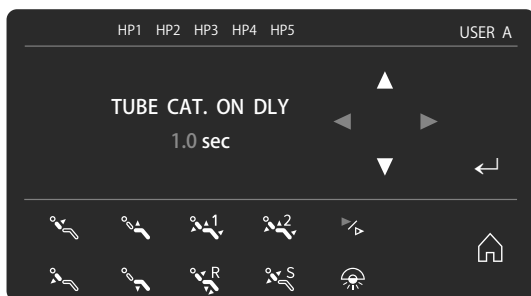

- ② The screen for changing the CATCH ON DELAY will be displayed.  
The current setting blinks blue.  
Set the delay period using the Up/Down arrows.  
Press Enter to confirm.

## ■ Factory Reset Setting

Resets individual user settings to factory settings



- ① Go to the FACTORY RESET settings screen.  
Press Enter.





- ② The screen for changing the FACTORY RESET setting will appear.  
The current setting blinks blue.  
Select using the Left/Right arrows.  
Press Enter to confirm.

## ■ RETURN MAIN MENU







- ① Go to the RETURN MAIN MENU screen.  
Press Enter to return to the home screen.

## 5 Caring for the Unit

 <b>WARNING</b>	
	Be sure to turn the main switch OFF when caring for/cleaning the main unit. Close the water supply valve and air supply valve as necessary. <ul style="list-style-type: none"><li>● Accidents and faults due to unforeseen circumstances/electric shock etc. may occur.</li></ul>
	Be sure to wear rubber gloves when caring for/cleaning the main unit to prevent infection. <ul style="list-style-type: none"><li>● An infection within the clinic may occur.</li></ul>
	Sterilize and properly wipe successive parts such as each instrument that come into contact with the oral cavity. <ul style="list-style-type: none"><li>● If proper sterilization and wiping are not carried out suitable hygiene management is not employed, a nosocomial infection may occur.</li></ul>
	When using equipment such as an autoclave, follow the operation instructions for each device. Use the following temperatures corresponding to the sterilization regulations. <ul style="list-style-type: none"><li>● Damage/faults both sterilized materials and equipment and an accident may occur.</li></ul>
	The recommended autoclave sterilization conditions described in these operation instructions do not guarantee sterility. Always carry out sterilization validation by yourself. <ul style="list-style-type: none"><li>● An infection within the clinic may occur.</li></ul>

### 5.1 Autoclave Sterilization

 <b>WARNING</b>	
	Clean the instrument before sterilization. <ul style="list-style-type: none"><li>● Insufficient sterilization may occur.</li></ul>
 <b>CAUTION</b>	
	When autoclave sterilization is carried out, put items in a mesh basket, tray, sterilization pack etc. so that the sterilized material does not directly come into contact with the inner walls of the chamber. For models with high drying and standby temperature, remove the chamber promptly when sterilization is not being carried out. <ul style="list-style-type: none"><li>● The inner wall of the chamber and the drying process may reach a higher temperature than the set sterilization temperature and damage to the sterilized material may occur.</li></ul>



## 5.1.1 Instrument Sterilization

### ⚠ CAUTION



If abnormalities such as deformation, degeneration, cracks etc. are found in any of sterilized parts, stop using the part and replace it with a new one. In particular, please note that the resin products of the vacuum syringe and VS nozzle and SE flexible nozzle of the saliva ejector will be worn out faster by repeated sterilization than parts made of metal/silicone.

- Continued use while there are abnormalities may cause problems such as accidents due to unforeseen damage.

Perform autoclave sterilization before and after treatment if necessary.

For details of the autoclave sterilization method, refer to the operation instructions of the relevant product.

Autoclave sterilization of the three-way syringe, vacuum syringe, and saliva ejector is carried out by removing the nozzle and tip from the main part. For the recommended conditions for autoclave sterilization refer to the following.

- Air turbine handpiece
- Micromotor attachment
- Micromotor motor cover
- How to remove the syringe case and nozzle of the three-way syringe (WS97,WS100,WS10-O-LD)

For removal: ④pp. 58-61

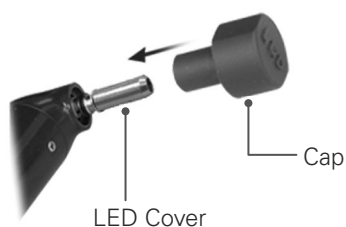

#### WS10-O-LD

Autoclaving can degrade the LED; put the cap on the LED cover before autoclaving.

- How to remove the syringe body, VS nozzle and VS tip of the vacuum syringe (VS110)  
For removal: ④pp. 127-129
- How to remove the ejector body and SE flexible nozzle the saliva ejector (SE110)  
For removal: ④pp. 130-131
- Ultrasonic scaler (handpiece, tip) **Option**

Sterilized site	Sterilization temperature	Sterilization period
Syringe case, nozzle of the three-way syringe (WS97,WS100)	134±1 °C	10 minutes or more
Syringe case, nozzle of the three-way syringe (WS10-O-LD)	134±1 °C	6 minutes or more
VS syringe, VS nozzle and VS tip of the vacuum syringe	134±1 °C	10 minutes or more
Ejector body of the saliva ejector, SE flexible nozzle	134±1 °C	10 minutes or more

## 5.1.2 Holder Cup Sterilization

Perform autoclave sterilization before and after treatment if necessary.

### ■ Doctor-side holder

Before removing the holder cup, turn OFF the main switch of the dental treatment unit, and remove the instrument.

#### Holder Cup Removal

- ① Press (1) the release button of each holder cup on the under side of the tray and remove the holder cup from above (2).

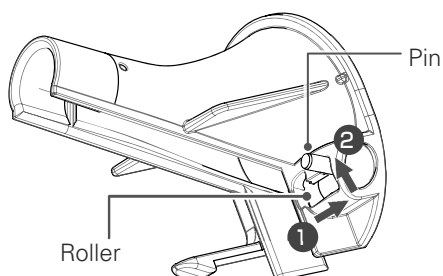
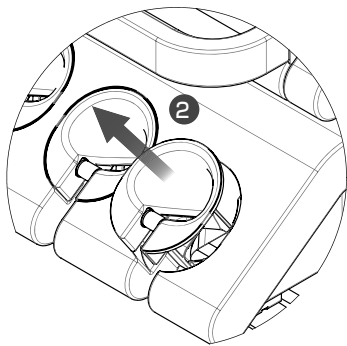
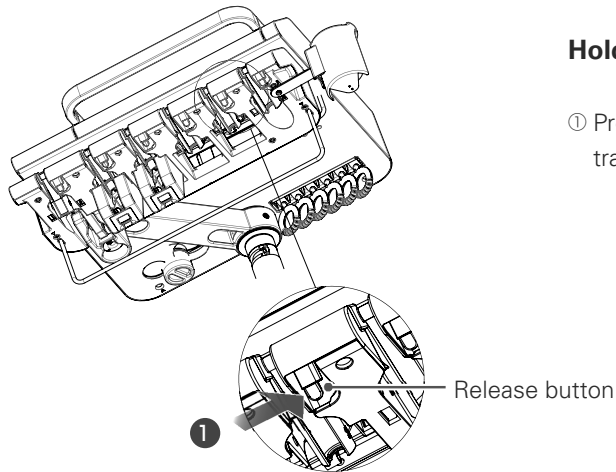

- ① Remove the instrument tube.  
Move the pin at the back of the holder cup in the order shown in the drawing (1 ⇒ 2) and retract the roller. Pull the pin up until you hear a click.  
Now remove the tube from the gap.

#### Autoclave sterilization

Recommended conditions  $134\pm 1^{\circ}\text{C}$ , 5 minutes or more

### Holder Cup Installation

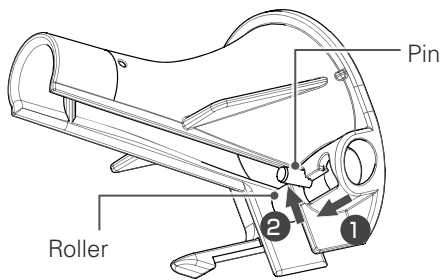

- ① Pass the instrument tube through the lower gap then pass it through the holder cup.

The shape of the holder cup differs for each instrument.

Check that the holder cup/tube combination is correct using the marking on the side of the cup holder.

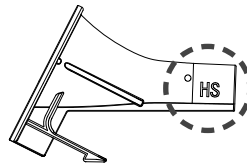

Instrument	Seal
Threeway syringe	WS
Air turbine	HS
Micromotor	LS/SC
Ultrasonic scaler (Solfy)	(SOLFY)
Ultrasonic scaler (Newtron)	SC (NEWTRON)

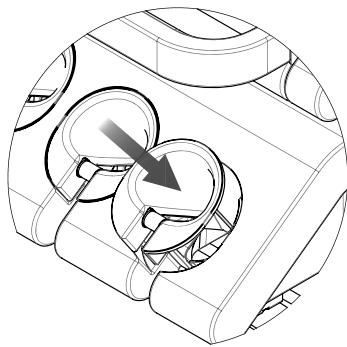

- ② Move the pin on the back of the holder cup in the order shown in the drawing (1) ⇒ (2) and remove the roller. Pull the pin up until you hear a click.

- ③ With the tube passed through the holder cup, fit the holder cup into the instrument holder.

Ensure that the holder cups are installed correctly in the original circuit order.

Push the holder cup in until you hear a click.

## Assistant-side holder

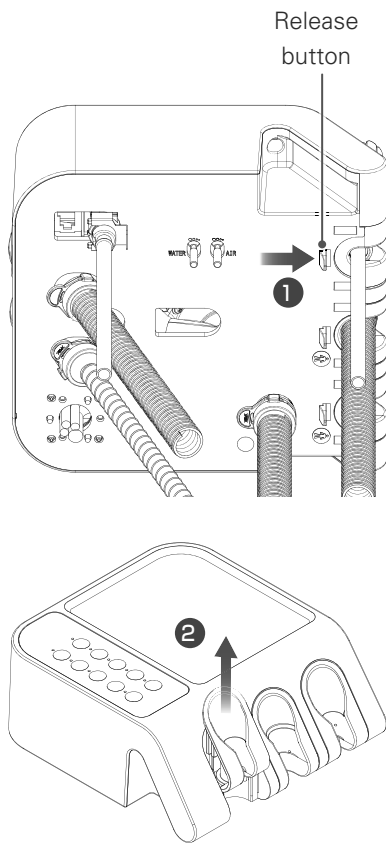

Before removing the holder cup, turn OFF the main switch of the dental treatment unit, and remove the instrument.

### Holder Cup Removal

- ① Press (1) the release button of each holder cup on the under side of the tray and remove the holder cup from above (2).

### Autoclave sterilization

Recommended conditions 134±1°C, 5 minutes or more

### Holder Cup Installation

- ① The shape of the holder cup differs for each instrument.  
Check that the holder cup/syringe combination is correct using the marking on the side of the holder cup.

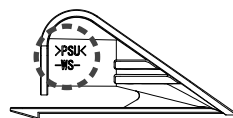
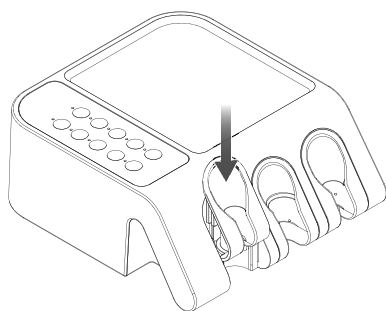

Instrument	Seal
Threeway syringe	WS
Vacuum syringe VS110	VS110
Saliva ejector SE110	SE

- ② Fit the holder cup to the instrument holder.  
Ensure that the holder cups are installed correctly in the original circuit order.  
Push the holder cup in until you hear a click.

### 5.1.3 Other Sterilization

Perform autoclave sterilization before and after treatment if necessary.

#### ■ Tray handle cover

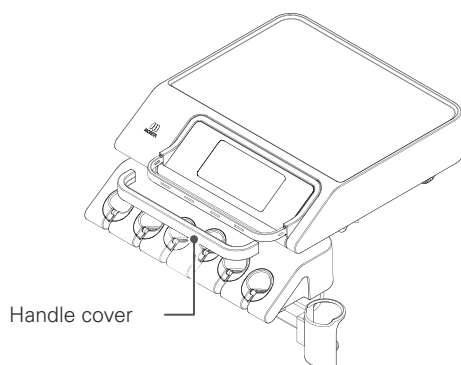

The silicone cover of the handle can be removed and sterilized using an autoclave.

When installing it, fit it to match the shape of the handle.

Autoclave sterilization recommended conditions:  $134\pm 1^{\circ}\text{C}$  5 minutes or more

#### ■ Operating Light Handle or Handle Cover

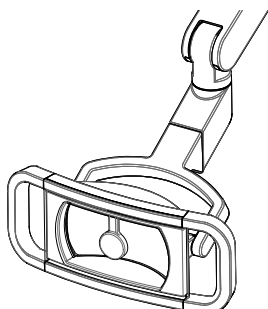

For details of the autoclave sterilization method, refer to the operation instructions of the relevant product.

#### ■ Silicone Tray Sheet Option



Autoclave sterilization recommended conditions:  $134\pm 1^{\circ}\text{C}$  5 minutes or more

#### ■ Vial holder Option



Autoclave sterilization recommended conditions:  $134\pm 1^{\circ}\text{C}$  5 minutes or more

## 5.2 Wiping with Disinfectant Ethanol

 CAUTION	
	<p>When cleaning with ethanol, always use disinfectant ethanol (76.9-81.4 vol%).</p> <ul style="list-style-type: none"> <li>● Using other ethanols, solvents etc. may cause degeneration/deterioration/faults.</li> </ul>
	<p>When cleaning with ethanol, please avoid the areas where ethanol may ingress such as the gaps around joint/rotation axes/switches.</p> <p>Do not use excessive ethanol for other parts.</p> <ul style="list-style-type: none"> <li>● Accidents due to a short circuit, degeneration, deterioration or damage may occur.</li> </ul> <p>After cleaning with ethanol, do not place with other products (for example, do not put a mouse pad on the silicone tray sheet). Dry thoroughly and store separately.</p> <ul style="list-style-type: none"> <li>● Color transfer from other products, deterioration may occur due to the effects of ethanol.</li> </ul>

### 5.2.1 Instrument Wiping

Wipe with disinfectant ethanol before and after treatment if necessary.

For details of the wiping method, refer to the operation instructions of the product.

- Air turbine handpiece
- Micromotor attachment
- Micromotor motor cover
- How to remove the syringe case and nozzle of the threeway syringe (WS97, WS10-O-LD, WS100/WS100LD)
  - For removal [pp.58-61](#)
- How to remove the syringe body, VS nozzle and VS tip of the vacuum syringe (VS110)
  - For removal [pp. 131-132](#)
- How to remove the ejector body and SE flexible nozzle the saliva ejector (SE110)
  - For removal: [pp. 133-134](#)
- Ultrasonic scaler (handpiece, tip) **Option**

## 5.2.2 Wiping the Leather Seat

### CAUTION

Do not subject the leather seat to the following conditions.

- ① Contact with clothing and bags containing dyestuffs such as real leather and denim  
(risk of discoloration due to color transfer/degeneration)
- ② Contact with vinyl/styrene/ABS/wood products/painted products  
(risk of discoloration and degeneration/cracks)
- ③ Contact with printed materials such as newspapers and magazines/printed pattern fabrics  
(risk of color transfer and disfiguration)
- ④ Contact and use of solvents/paints/chemicals/adhesives/adhesive tapes etc.  
(damage and deformation/discoloration/degeneration/hardening/softening)
- ⑤ Use of bleach  
(risk of discoloration and degeneration)
- ⑥ Contact with or proximity to a heat source such as an iron or a stove  
(damage and deformation/discoloration/degeneration)
- ⑦ Partial loading due to being pressed against, scuffed, etc.  
(damage and deformation/discoloration/degeneration)
- This may cause damage/degeneration/discoloration etc. of the leather seat or other parts.

- ① Wipe using a soft cloth or sponge containing a small amount of disinfectant ethanol, the supplied cleaning agent, a neutral detergent, or water.
- ② Then, wipe with a dry cloth, taking care not to leave any residual moisture or detergent.

Please note that leather seats of certain colors are not compatible with disinfectant ethanol.

### 5.2.3 Wiping Other Parts

Wipe with disinfectant ethanol before and after treatment if necessary.



Wipe with a soft cloth such as gauze containing a small amount of disinfectant ethanol.

Wring out the cloth so it does not contain an excessive amount of disinfectant ethanol.

- Operating Light Handle or Handle Cover
  - Operating Light Main Surface
  - NOTE: For details of the wiping method, refer to the operation instructions for the product.
- Basin/catch
- Instrument main tube
- Disassembly of instrument holder (doctor side/assistant side)
  - For disassembling ⓘpp. 112-113
- Silicone tray sheet
- Vial holder
- Display panel/assistant-side operation panel
- Flushing adapter
- Assistant-side armrest
- Doctor-side armrest **Option**



### 5.3 Other Cleaning Methods

 <b>CAUTION</b>	
	Do not dry heat (with dry sterilizer)/sterilize the various parts of the main unit. <ul style="list-style-type: none"><li>● Discoloration/deterioration/faults may occur due to the high temperature.</li></ul>
	Do not soak, rinse, or boil any part of the main unit with a cleanser containing disinfectant ethanol or solvent (such as benzine or a thinner). <ul style="list-style-type: none"><li>● Discoloration/deterioration/faults may occur.</li></ul>

Other sterilization/disinfection methods may have adverse effects on the main unit and parts.  
Consult your reseller or the nearest MORITA CORP. subsidiary in advance.

## 5.4 Everyday Maintenance (before treatment)

### ⚠ CAUTION



Once a day, before commencing treatment, drain residual water from the main unit using the following procedure.

Take particular care after if the water has been there for a longer period, such as the day after a holiday.

- Since a certain amount of water remains in the warmer tank and tubes of the main unit and the quality of water will decrease if it is left for a long period, the remaining water should be discharged before use.

Before commencing daily treatment, drain residual water from the main unit from each water line.

### 5.4.1 Flushing of Residual Water

#### ■ Manual flushing

Water remaining in the water lines is flushed manually.

Carry out in the following procedures in the given order. If you do not follow this order, the flushing process will be less efficient.

“Flushing the cup water supply”



“Flushing the threeway syringe circuit”



“Flushing the air turbine handpiece circuit”



“Flushing the micromotor circuit”



“Flushing the ultrasonic scaler **Option** circuit”

#### Estimated flushing times for each water line

Water line		Estimate
1	Cup water supply	At least 1 minute
2	Threeway syringe	At least 1 minute for each
3	Air turbine	At least 1 minute for each
4	Micromotor	At least 2 minutes for each
5	Ultrasonic scaler	At least 3 minutes

The time required to flush each water line (refer to the table on the right) depends on the quantity of water within the main unit.

Besides the water in the main body of the unit, there may be water in the piping and so we recommend that you flush the circuits for longer than is specified in the table.

#### Flushing the Cup Water Supply

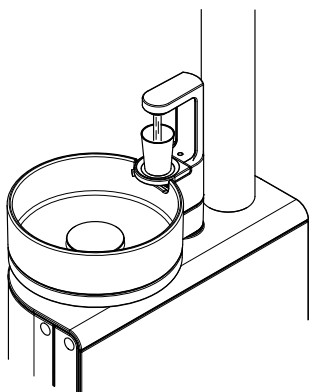

- ① Place a cup on the cup stand and supply Estiwater.
- ② When the supply of water has finished, discard the water in the cup and supply water again.  
Repeat this 8 times or more.
- ③ Do the same for the water supply using the manual water supply switch.  
In this case, supply water for 1 minute or more.

### Threeway syringe circuit residual water drainage

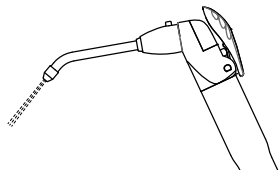

- ① Remove the threeway syringe from the instrument holder.
- ② Point the tip of the syringe toward the basin, push the W lever and flush for at least 1 minute.
- ③ Do this for the both doctor side and assistant side.
- ④ When finished, placed the threeway syringe in the instrument holder.

### Flushing the air turbine circuit

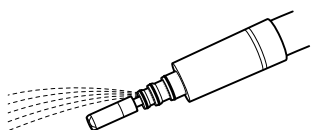

- ① Remove the handpiece from the instrument holder.
- ② Press the water injection ON/OFF icon on the display panel.
- ③ Remove the air turbine from the tube.
- ④ Point the tip of the tube toward the basin, step on the foot control pedal, and flush for at least 1 minute.
- ⑤ On completion, connect the air turbine to the tube, and place it in the instrument holder.

If there is a second circuit (option), follow the same procedure.

### Flushing the micromotor circuit

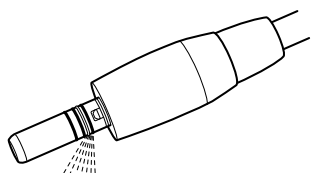

- ① Remove the micromotor from the instrument holder.
- ② Press the water injection ON/OFF icon on the display panel.
- ③ Remove the straight handpiece and contra-angle handpiece from the micromotor.
- ④ Point the water supply port at the tip of the micromotor towards the basin, press the foot control pedal and flush for at least 2 minutes.  
The water supply port is located beside the connecting tube. Check the position then flush.
- ⑤ When finished, place the motor in the instrument holder.

If there is a second circuit (option), follow the same procedure.

### Flushing the ultrasonic scaler circuit

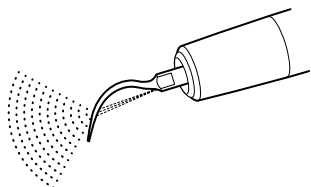

#### ⚠ CAUTION



When flushing, always be sure to attach the ultrasonic scaler main body to the tube with the tip attached.

- If vibration is started with the tip removed, an excessive load is applied to the circuit board and other parts of the device, and a fault may occur.

- ① Remove the ultrasonic scaler from the instrument holder.
- ② Press the water injection ON/OFF icon on the display panel.
- ③ Point the tip of the ultrasonic scaler toward the basin, step on the foot control pedal, and flush for at least 3 minutes.
- ④ When finished, remove the tip from the ultrasonic scaler and place the scaler in the instrument holder.

## Flushing with the flushing device Option

Every day prior to commencing treatment, each water line needs to be flushed (residual water needs to be removed from piping).

### 1. Flushing preparation

Move the doctor-side tray closer to the basin side so that each tube reaches the flushing device.

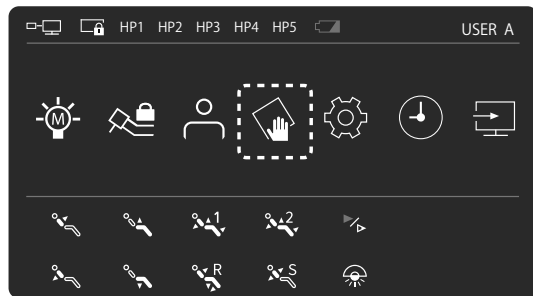

① Operate using the tray display panel.

On the home screen, press the flushing icon.



② The flushing preparation screen appears.

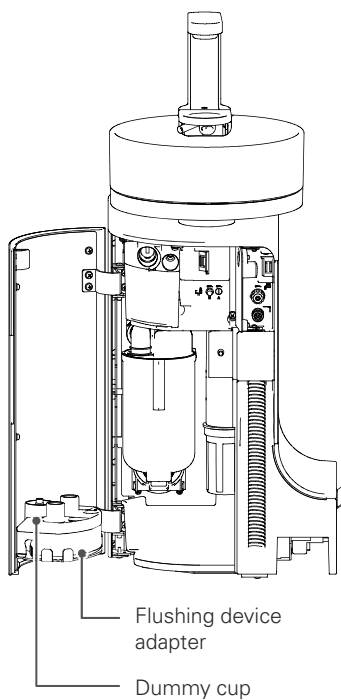

### 2. Flushing device/dummy cup set

Open the unit door and remove the flushing device adapter and dummy cup. Position the removed flushing device on the basin.

Hook the flushing device on the edge of the basin in the position shown below.

Also position the dummy cup on the automatic filler. Position it with the small port facing down.

NOTE: Depending on some specifications, the flushing device adapter may not be able to be stored in the unit

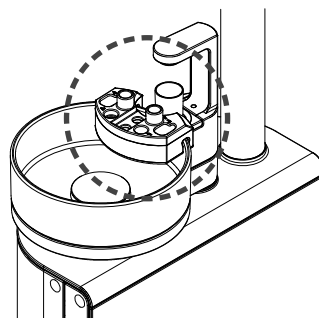

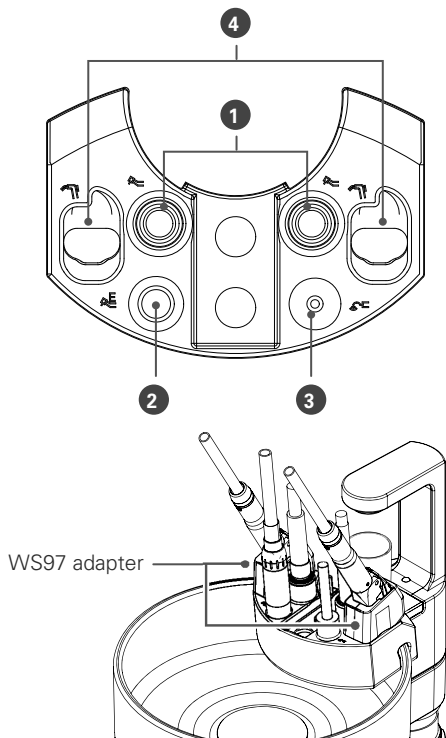





### 3. Setting Up Tubes

Set up the tubes in the flushing device.

For how to remove of the instruments and attachments from the tubes, please refer to the table below.

Thereafter, insert each tube into the corresponding hole in the flushing device adapter, taking care to keep the tub straight and insert it fully.

If the threeway syringe is WS97, attach the WS97 adapter to the flushing device adapter.

Connection to the flushing device adapter			
Display	Site	Preparation of tube	
Tube for air turbine		①	Remove the air turbine
Tube for micromotor		②	Remove the attachment
Tube for ultrasonic scaler		③	Remove the ultrasonic scaler
Tube for threeway syringe		④	Remove the nozzle

### 4. Flushing operation

Select START using the Left arrow and press Enter to start flushing.

Any water remaining in the pipeline is automatically discharged in the following processes.

"Flush cup water supply" (about 150 seconds)



"Flush assistant-side threeway syringe circuit" (about 45 seconds)



"Flush doctor-side threeway syringe circuit" (about 110 seconds)



"Flush instrument circuit [5th circuit]" (about 40 seconds)



"Flush instrument circuit [4th circuit]" (about 30 seconds)



"Flush instrument circuit [3rd circuit]" (about 30 seconds)



"Flush instrument circuit [2nd circuit]" (about 30 seconds)



"Flush Instrument circuit [1st circuit] residual water drainage" (about 30 seconds)



Completion

NOTE: If there is a circuit with no setting, it is skipped.

NOTE: If there is a circuit with no setting, the flushing time may differ from the above.

NOTE: If you turn off the chair unit before starting and resume operation, the panel display will be the instrument's pickup display. To switch to the flushing start screen, press and hold the water injection switch.

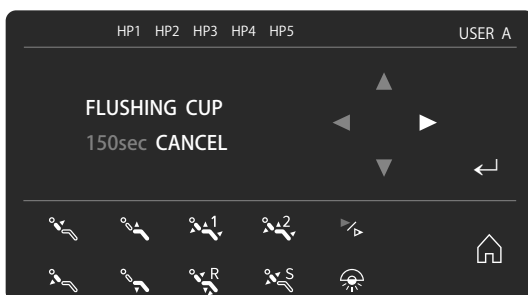

Example: cup water supply

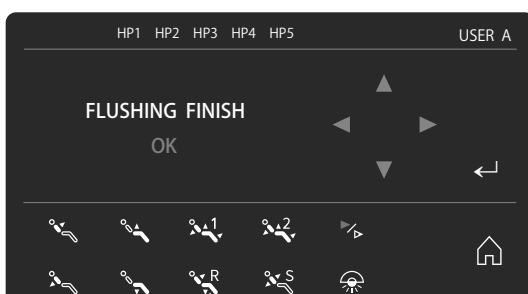

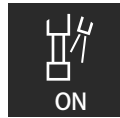

NOTE: If there is a circuit with no setting, it is skipped.

NOTE: If there is a circuit with no setting, the flushing time may differ from the above.

NOTE: If you turn off the chair unit before starting and resume operation, the panel display will be the instrument's pickup display. To switch to the flushing start screen, press and hold the water injection switch.

## 5. Interrupting the Flushing Process Partway Through



① Press the Right arrow.

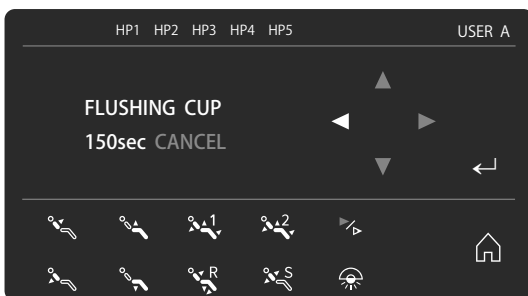

② "CANCEL" will turn blue.

In this state, press Enter to stop the flushing process and return to the flushing preparation screen.

## 6. Tube Removal

Remove each tube from the flushing device place it in the instrument holder as before.

Store the flushing device adapter and dummy cup inside the unit as before.

## 5.5 Everyday Maintenance (between patients)

### 5.5.1 Vacuum System Rinsing

#### ■ Vacuum system rinsing

Flush the vacuum syringe and the saliva ejector piping with tap water.

If the inside of the vacuum tube becomes dirty, loss of suction power, failure, clogging etc. may occur.

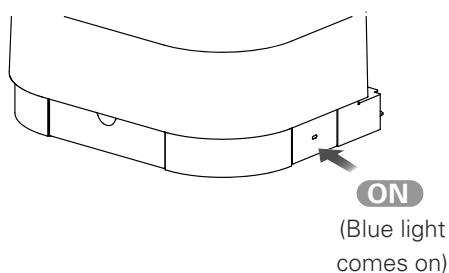

- ① Turn the main switch ON.
- ② Please confirm that you have chosen WATER for vacuum system cleaning in COMMON SETTING. If you have chosen CLEANSER for vacuum system cleaning, switch it to WATER please. ☞P. 96



- ③ Remove the VC nozzle and SE nozzle from the vacuum syringe and the saliva ejector. And take them from holders. The vacuum system will work as soon as the vacuum syringe and the saliva ejector are taken from their holders. For stopping suction, press VACUUM SYRINGE SUCTION switch please. Open the unit door, and insert the vacuum syringe and the saliva ejector into the connection holes of the water supply tank. At this time, leave each adjustment lever fully open.

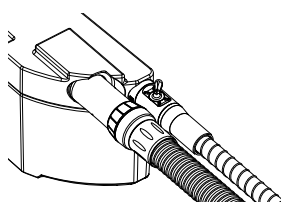
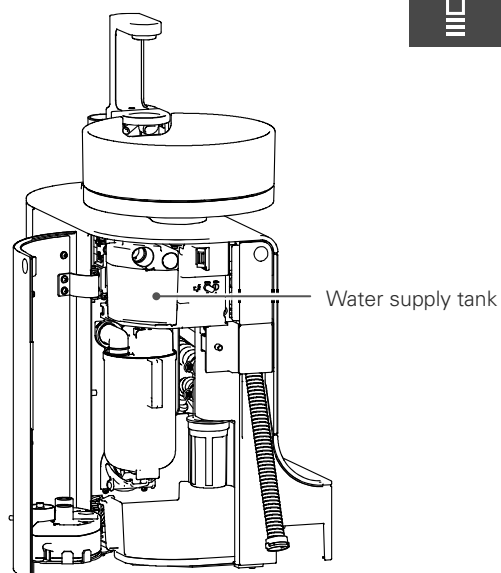

- ④ Press the vacuum system rinse switch on the assistant-side operation panel to start rinsing the piping.
- ⑤ When rinsing has finished, remove the vacuum syringe and saliva ejector from the water supply tank and put them back in their holders.

## ■ Rinsing the vacuum piping with cleanser

### ⚠ CAUTION



For the vacuum system cleanser, use "Mazak P" specified by MORITA.

Follow the instructions supplied with the cleanser.

- Failure to follow these instructions may lead to damage to the circuits or tubes, and damage, faults, water leaks or loss of suction may occur.

Rinse vacuum syringe and saliva ejector piping with cleanser.

If the inside of the vacuum tube becomes dirty, loss of suction power, failure, clogging etc. may occur.

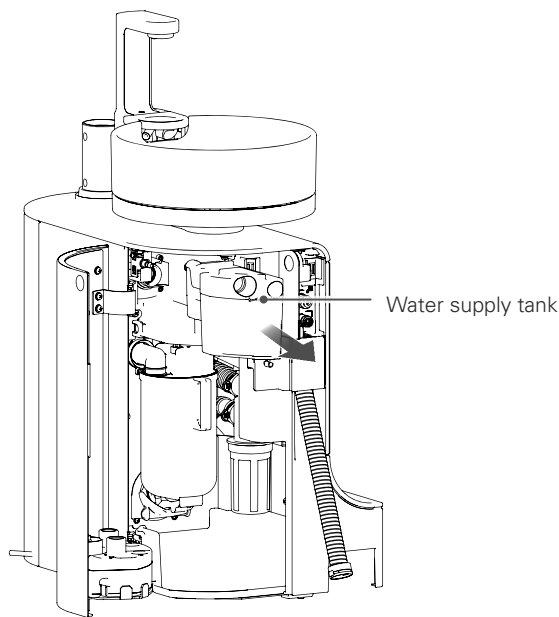

- ① Turn the main switch ON.
- ② Please confirm that you have chosen CLEANSER for vacuum system cleaning in COMMON SETTING. If you have chosen WATER for vacuum system cleaning, switch it to CLEANSER please. ☞p. 95
- ③ Open the unit door, and remove the water supply tank.

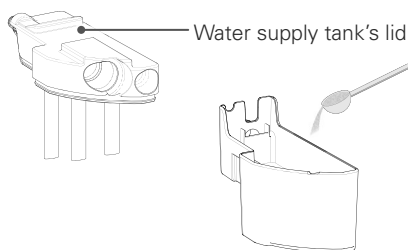

- ④ Remove the water supply tank's lid and add 200 mL water or lukewarm water (approx. 40°C), to stir and dissolve them with a stirring stick. If too much water is added in at this point, the cleansing liquid or bubbles may overflow. When the stirring is finished, replace the water supply tank's lid as before.

If it is hard to fit the water supply tank into the unit, apply Vaseline on the O-rings of water supply tank.

Do not use a cleanser other than Mazak P as a malfunction may occur. Refer also to the operation instructions for Mazak P.

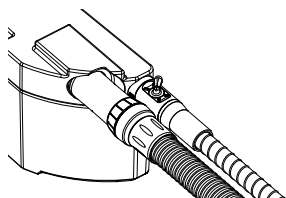

- ⑤ Remove the VC nozzle and SE nozzle from the vacuum syringe and the saliva ejector. And take them from their holders. The vacuum system will work as soon as the vacuum syringe and the saliva ejector are taken from their holders. For stopping suction, press VACUUM SYRINGE SUCTION switch please.

Insert the vacuum syringe and the saliva ejector into the connection holes of the water supply tank. At this time, leave each adjustment lever fully open.



- ⑥ Press the vacuum system rinse switch on the assistant-side operation panel to start rinsing the system piping. (At this time, about 100 mL of water will be automatically added)

- ⑦ When cleaning is finished, remove the vacuum syringe and saliva ejector from the water supply tank and return them to their instrument holders.



## 5.5.2 Automatic Rinsing of Vacuum Tank

Automatically rinse out the inside of the vacuum tank with air and running water.



- ① Press the vacuum tank automatic rinsing switch on the assistant-side operation panel.
- ② Rinsing starts automatically, continues for a certain period of time, then stops automatically.  
To stop it part way through, press the switch again.

## 5.6 Everyday Maintenance (after use)

### 5.6.1 Cleaning the Vacuum Filter

#### ⚠ CAUTION



When installing the vacuum filter, be sure it is fully inserted.

- If the vacuum filter is not fitted properly, the performance of the vacuum syringe/saliva ejector may be adversely effective, or a malfunction/clogging etc. may occur.

Every day after use, clean the vacuum filter on the assistant-side holder.

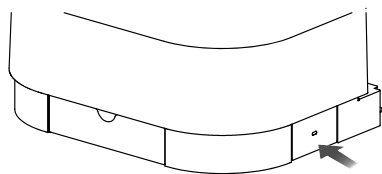

**OFF**

(Blue light goes off)

- ① Turn the main switch OFF.

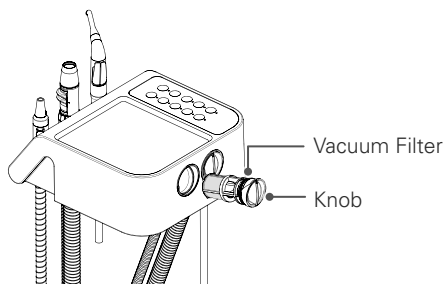

- ② Clean each vacuum pipeline and saliva ejector pipeline.  
Remove the vacuum filter on the assistant-side holder side.  
Grip the knob and pull it straight out.

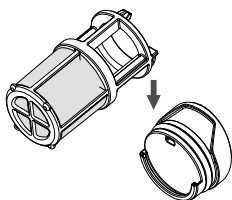

- ③ Slide the knob part of the vacuum filter in the direction of the arrow to disassemble.  
After disassembling, rinse in running water.  
The cut filter is a consumable part. There is a risk of injury if the net is torn or frayed, replace it with a new one.

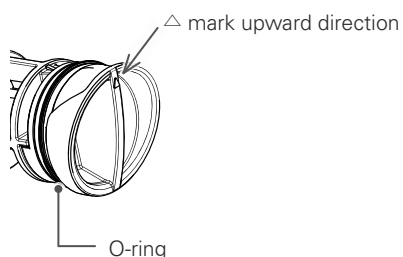

- ④ After rinsing, assemble as before.  
After assembly, insert it back into the assistant-side holder.  
With the △ mark on the front of the knob facing upward, push the filter in as far as it will go.  
If insertion is difficult, apply Vaseline to the knob around the O-ring.

## 5.6.2 Cleaning the Basin

### ■ Cleaning the catch and filter

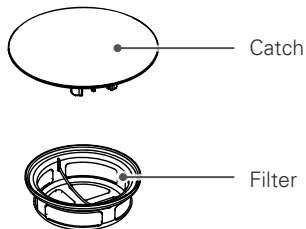

- ① Remove the catch and remove the filter from the waste water port.
- ② Rinse the catch and filter under running water.
- ③ Install the catch and filter as before.  
Press the filter firmly until it is fully inserted.

### ■ Basin Removal

The basin can be removed for cleaning. Refer to the following procedure.

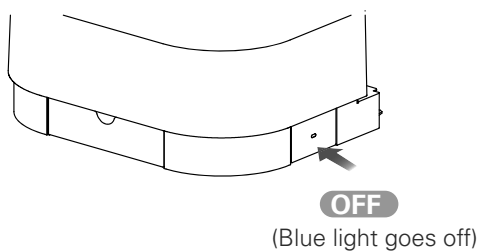

- ① Turn the main switch OFF.

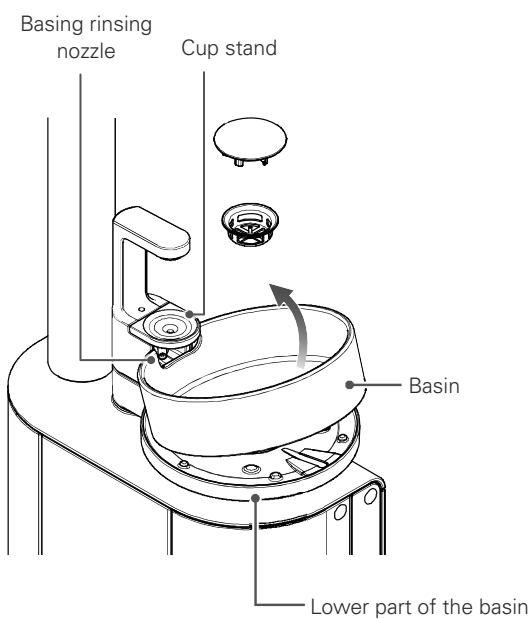

- ② Remove the catch and filter.
- ③ Remove the basin.  
The basin fits into the packing of the basin lower part waste water port. While holding the lower part of the basin, lift the basin bowl upward. At this point, if you lift straight up, the basin bowl will make contact with the cup stand and basin rinsing nozzle. Be careful to avoid this when removing the basin bowl.

Note also that if you pull up on the basin bowl without pushing down on the lower part of the basin, there is a risk of a fault occurring in the swivel mechanism.

An anti-fouling coating has been applied to the underside of the basin bowl. Note that it will peel off if rubbed or scratched.

## ■ Cleaning the Basin

### ⚠ CAUTION



When cleaning the basin, do not use detergents containing abrasives, or hard cleaning materials such as a scourer/steel wool. Do not strongly rub it.

- Damage, scratching, and discoloration may occur.

Wipe off using a soft cloth impregnated with a small amount of the supplied cleaning agent (or a neutral detergent), disinfectant ethanol, or water.

Then wipe dry with a dry cloth so that no moisture remains.

## ■ Basin Installation

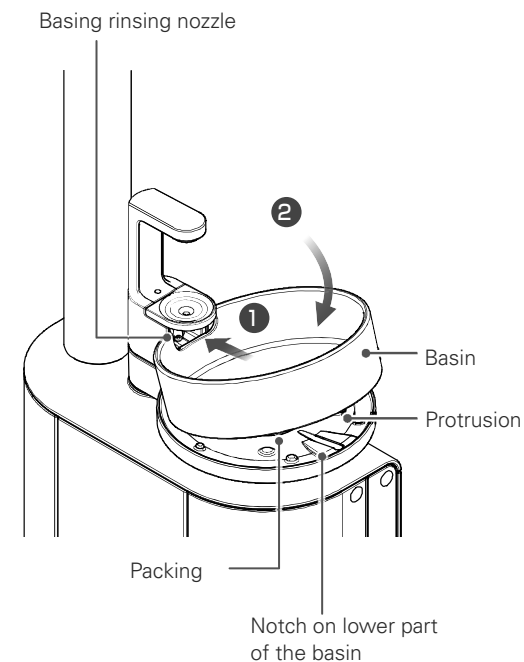

- ① Align the protrusion on the back of the basin with the notch on the base of the basin.

Insert the basin under the basin rinsing nozzle (1) and then insert it into the packing of the lower part of the basin waste water port (2).

If the basin is not sufficiently pushed into the packing, there is a risk of water leakage so push the basin in until fully fitted.

If the basin is difficult to fit into the packing, apply Vaseline to the packing.

- ② Then attach the filter and catch as before.

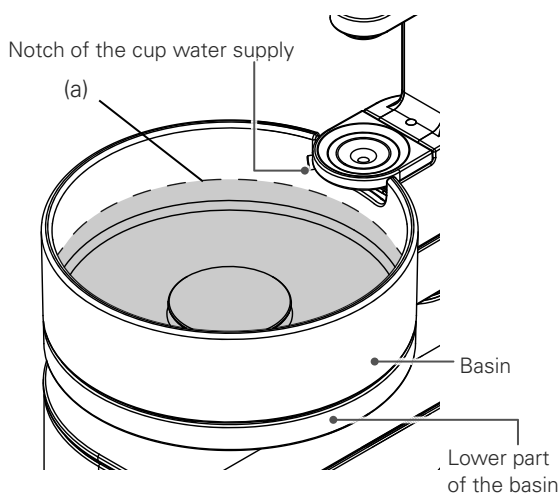

### Caution

Do not flush a large amount of water into the basin at once.

Amount as a guide: Intermediate position between the basin bottom and notch of the cup water supply. (a)

If water exceeds this position, it may not be able to be exhausted and water may flow into the gap between the basin and lower part of the basin.

If water flows into the gap between the basin and the lower part of the basin, wipe it off.

### 5.6.3 Vacuum Syringe Disassembly and Cleaning

#### ⚠ CAUTION



Do not use ultrasonic cleaning when disassembling and cleaning the adjustment lever. Do not scratch parts surfaces strongly with sharp instruments.

- The surfaces may be damaged and this may interfere with operation.

If the adjustment lever is stiff after performing a treatment, disassemble and clean the vacuum syringe.

#### ■ Disassembly and Cleaning Method (VS110)

##### 1. Disassembly

- ① Remove the vacuum syringe from the hose.  
Loosen the cover nut on the hose and pull the vacuum syringe straight out.

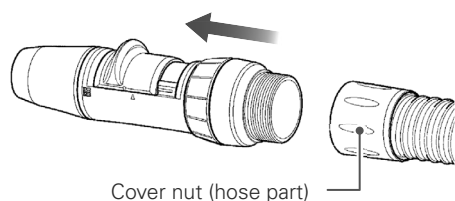

- ② Disassemble the tip fitting, drum case, and hose fitting.  
To remove the tip fitting, hold the drum case then loosen the tip fitting by turning it in the direction of the arrow.  
To remove the hose fitting, hold the hose fitting, turn the drum case lock nut in the direction of the arrow to loosen.

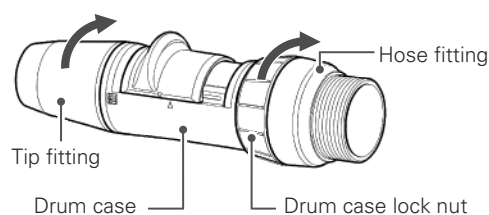

- ③ Take the drum receiver out of the drum case.  
Pull the drum receiver straight out of the end of the drum case.  
Note that the butterfly drum in the drum receiver cannot be disassembled.

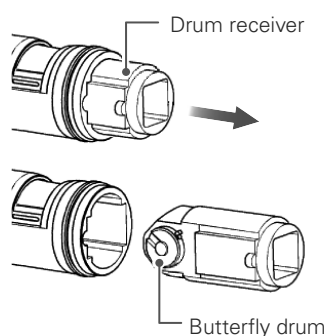

- ④ Disassemble the adjustment lever and drum case lock nut from the drum case.  
Match the  $\triangle$  mark on the adjustment lever to the  $\triangle$  mark on the drum case and pull it upward to remove (1).  
Then pull out the drum case lock nut in the direction of the arrow (2).  
The drum case lock nut can not be removed with the adjustment lever fitted.

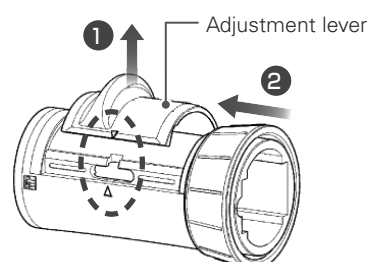

## 2. Rinsing the Parts

Rinse each disassembled part with running water.

Carefully remove hardened adhesions using a toothbrush etc.

After rinsing, apply a small amount of Vaseline to the drum receiver and O-rings in each part to make movement easy.

## 3. Assembly

After cleaning is finished, assemble the parts as before.

- ① Pass the drum case lock nut over the drum case.

If the adjustment lever is fitted first, the drum case lock nut can not be passed over the drum case.

- ② Fit the adjustment lever to the drum case.

The lever must be fitted with the correct orientation. Assemble as shown in the figure on the right.

Align the  $\triangle$  and  $\triangle$  marks and push it until you hear a click.

- ③ Position the drum receiver in the drum case.

Slide the adjustment lever in the tip direction (tip fitting direction) until it connects (①).

Align the stopper on the side of the butterfly drum to the position shown in the figure on the right (②).

Now, align the notch (③) on the drum receiver with the protrusion (④) on the drum case.

- ④ Insert the drum receiver into the drum case (⑤).

The pin on the inner side of the adjustment lever and the groove on the side of the butterfly drum engage, allowing the butterfly drum to rotate. Move the lever and check that the butterfly drum rotates.

- ⑤ Connect the tip fitting and hose fitting to the drum case.

After connecting, tighten the tip fitting and drum case lock nut in the direction of the arrows.

- ⑥ Connect the vacuum syringe and hose.

After connecting the vacuum syringe and hose, securely tighten the hose cover nut.

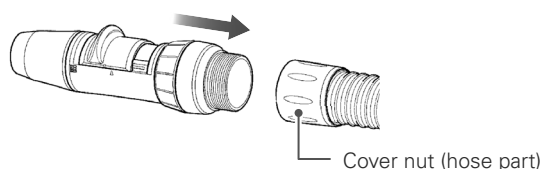
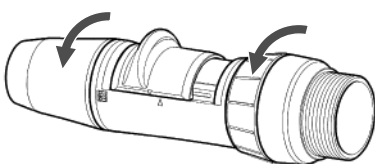
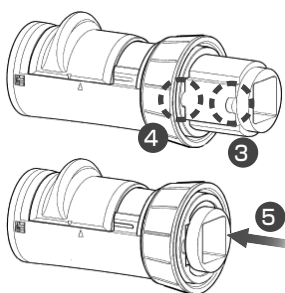
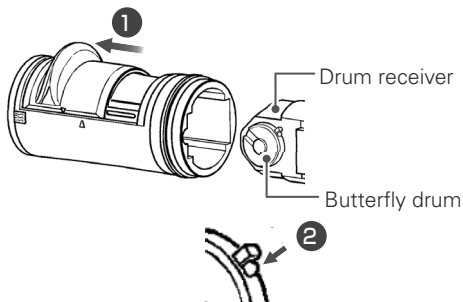
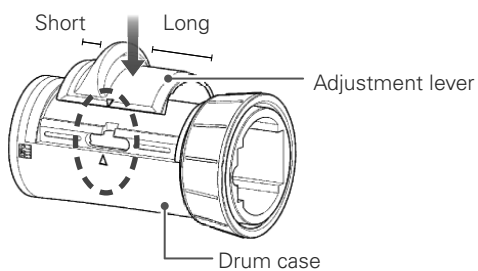
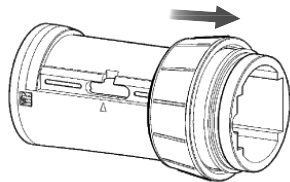

## 5.6.4 Disassembly and Cleaning the Saliva Ejector

If the adjustment lever is stiff after performing a treatment, disassemble and clean the saliva ejector.

### ■ Disassembly and Cleaning Method (SE110)

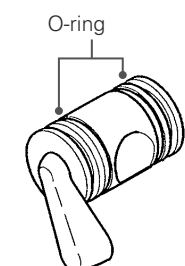
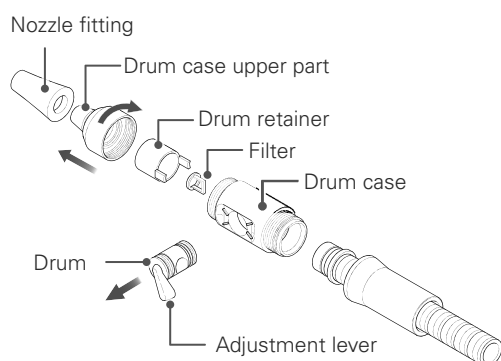
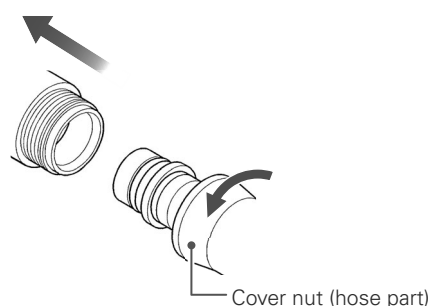

#### 1. Disassembly

- ① Remove the ejector body from the hose.  
Loosen the hose cover nut and pull off the syringe body in the direction of the arrow.
- ② Disassemble the ejector body.  
Loosen the drum case upper part in the direction of the arrow and remove it.
- ③ Press the drum retainer and remove the filter.
- ④ Remove the drum from the drum case.  
Push the flat surface on the opposite side of the drum lever and push it out.  
Note that if you do not remove the drum retainer, the drum cannot be removed.
- ⑤ Pull the nozzle fitting off the drum case upper part.

#### 2. Cleaning the Parts

Rinse each part of the disassembled saliva ejector with running water.

Carefully remove hardened adhesions using a toothbrush etc.  
After rinsing, apply a small amount of Vaseline to the drum surface and O-rings in each part to make movement easy.

Check the condition of the O-rings at both ends of the drum. Replace them if they are deformed/hardened/missing etc.

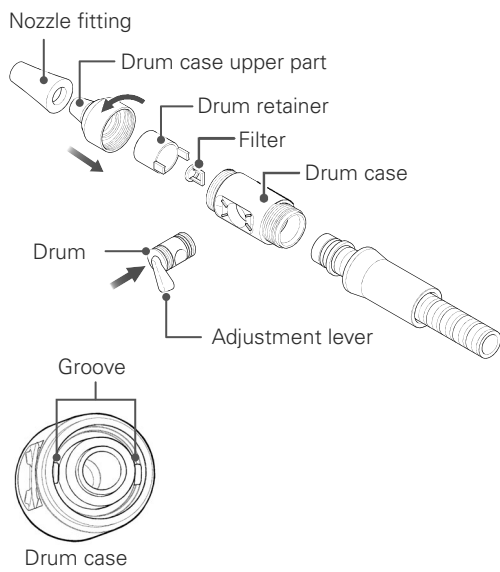

### 3. Assembly

After cleaning is finished, assemble the parts as before.

- ① Insert the drum in the drum case.
- ② Place the drum retainer in the drum case.  
At this time, insert the drum retainer tabs into the grooves on the inside of the drum case.
- ③ Insert the filter in the drum case.
- ④ Install the drum case upper part on the drum case.  
Tighten in the direction of the arrow to attach.
- ⑤ Fit the nozzle fitting to the drum case upper part.

After assembly, check whether the adjustment lever can be operated normally.

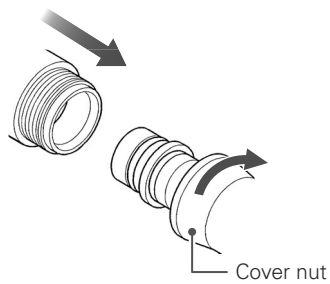

- ⑥ Connect the hose and the assembled ejector body.  
After firmly inserting the tip of the hose into the ejector body, tighten the cover nut in the direction of the arrow.



## 5.7 Monthly Maintenance

### 5.7.1 Cleaning the Water Supply Tank

Clean the water supply tank inside the unit at least once a month.

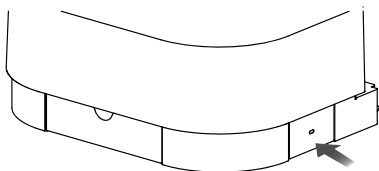

**OFF**  
(Blue light goes off)

① Turn the main switch OFF.

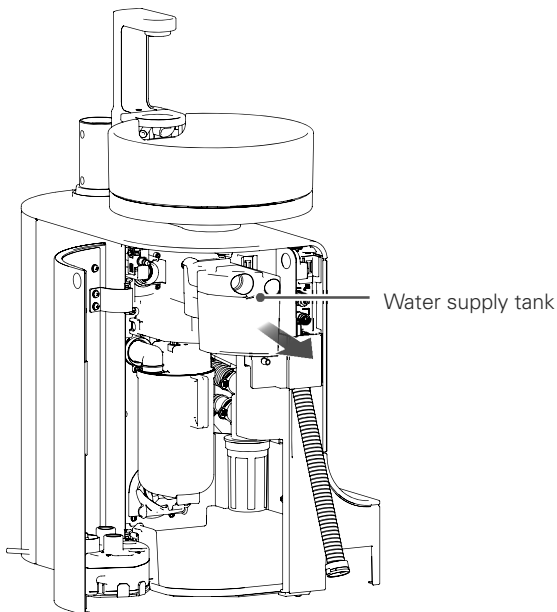

② Pull out and remove the water supply tank.

③ Disassemble the water supply tank and rinse out with running water.

④ Reassemble the water supply tank.

Fit the level surface of the suction pipe into the water supply tank lid.

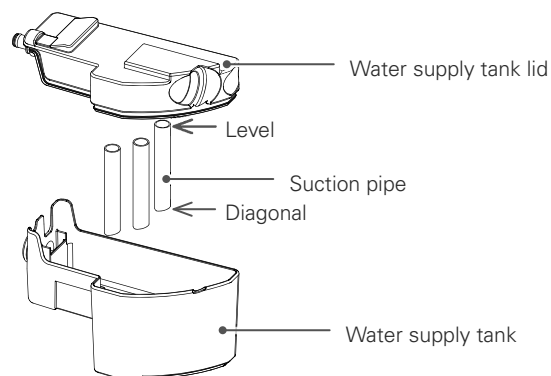

⑤ After cleaning, apply Vaseline on the O-rings of water supply tank, Install the water supply tank in the unit part as before.

Correct

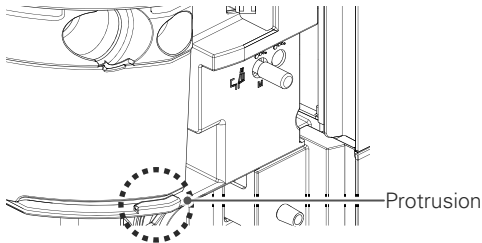

Incorrect

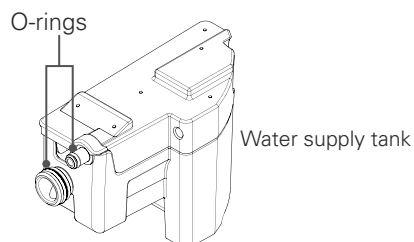
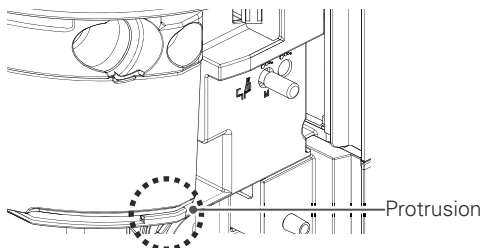

⑥ Push the Water supply tank into the unit as far as it will go. Attach to the back of the protrusion.

## 5.7.2 Checking and Cleaning the Vacuum Tank

### ⚠ CAUTION



Clean the inside of the vacuum tank once or more every 6 months.

- Failure to do so may lead to a drop in performance, faults/pipe obstruction etc.

Securely install the vacuum tank.

- Inadequate installation may reduce the level of performance of the vacuum syringe/saliva ejector, or result in a leak/fault/clogging etc.

Check inside the vacuum tank at least once a month and clean as necessary.  
Clean the inside of the vacuum tank at least once every 6 months.

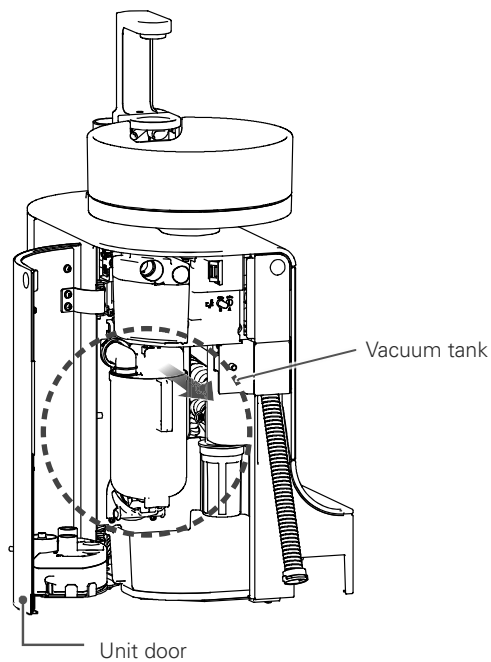

### 1. Removing the Vacuum Tank

- ① Turn the main switch OFF.
- ② Open the unit door.  
Hold the handle of the vacuum tank and remove the tank by pulling it away from the parts above.  
As effluent may spill, spread a rag under the tank.

### 2. Removing the Tank Lid

Hold the vacuum tank firmly, turn the tank lid in the direction of the arrow, and pull up straight up to remove it.

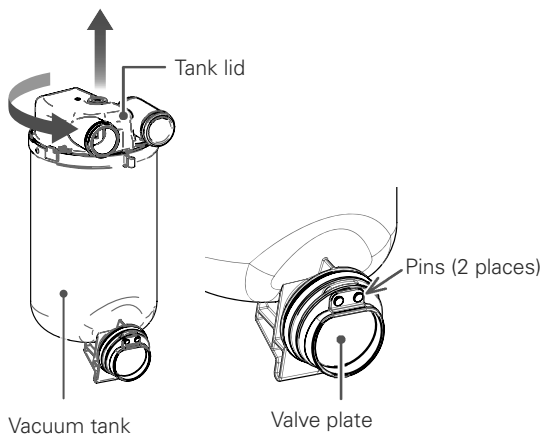

### 3. Cleaning the Vacuum Tank

- ① Rinse out the inside of the vacuum tank with running water.
- ② Remove the valve plate at the bottom of the vacuum tank and clean it.  
Rinse the surface of the valve plate on the vacuum tank side.  
When attaching the valve plate, position the flat surface to the vacuum tank side and fit the pins (2 places).

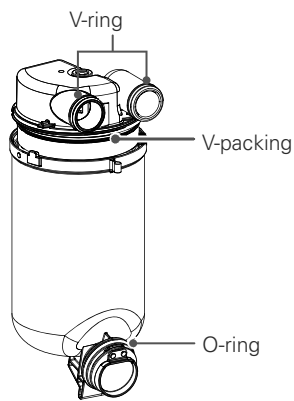

#### 4. Installing the Tank Lid

① Apply Vaseline to the rings of the tank lid and vacuum tank.

② Align the matching marks (protrusions) on the top of the tank lid with the side of the vacuum tank (①), fit the tank lid straight, and rotate it in the direction of the arrow (②).

After rotation, make sure that the tank lid fittings and vacuum tank fitting face in the same direction.

Make sure that the tank lid is securely tightened.

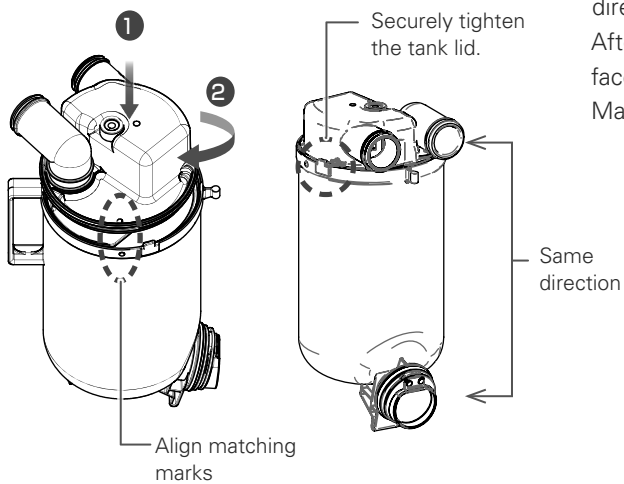

#### 5. Installing the Vacuum Tank

Align the lower part of the vacuum tank with the underside of the mounting part on the unit (①) and push the upper part of the vacuum tank to fit it (②).

Make sure the vacuum tank is fitted securely.

When finished, close the unit door.

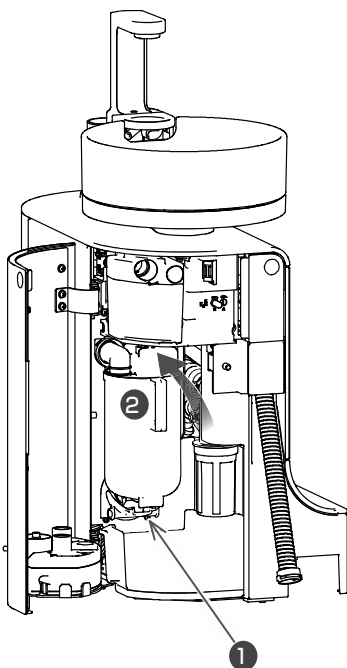

### 5.7.3 Amalgam separator

Option

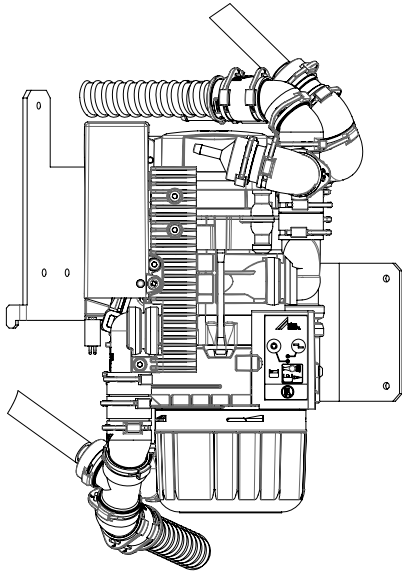

Please do not turn on the main switch with the cup set in the auto filler. The exchange sign of the amalgam separator may cause a false reaction. In this case, with the cup removed from the auto filler, please turn on the main switch again.

To prevent malfunction of the amalgam separator, water is not supplied for about 15 seconds after the main switch is turned on. During this time, auto filler and water injection will not come out, but it is not a malfunction.

## 5.7.4 Spittoon Valve

Option

Please follow the directions in the manual.

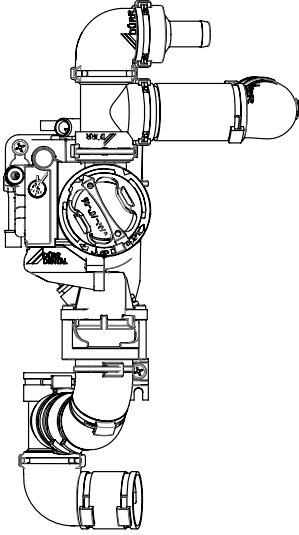

## 5.7.5 Cleaning Inside the Drain Trap

### ⚠ CAUTION



Clean the inside of the drain trap at least once a month.

- Failure to do so may lead to a drop in performance, faults/clogging etc.

Be sure to install the drain trap filter and filter case.

- If not properly installed, a water leak/damage/fault may occur.

Clean the drain trap inside the unit at least once a month or if you notice that drainage from the basin is poor.

- ① Turn the main switch OFF.

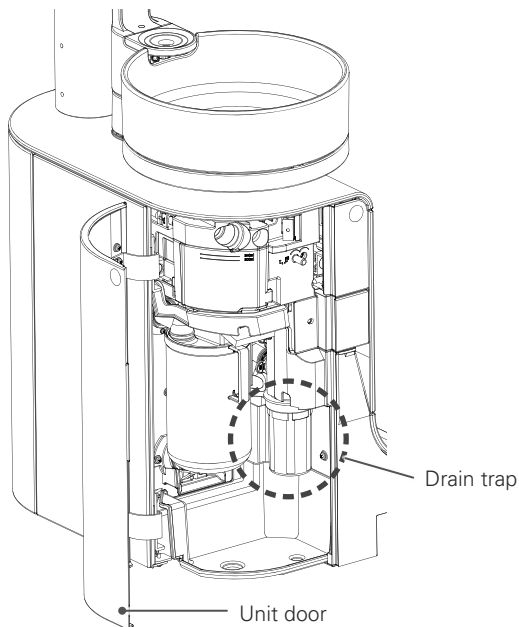

- ② Open the unit door and remove the filter case of the drain trap.

Turn in the direction of the arrow to loosen the filter case and release the lock.

Since effluent is collected in the filter case, be sure to pull it off in a downward direction and without tilting it.

Remove the filter case and trap filter assembly.

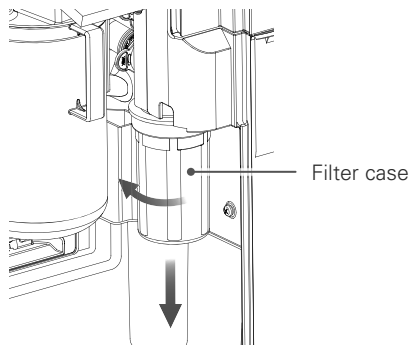

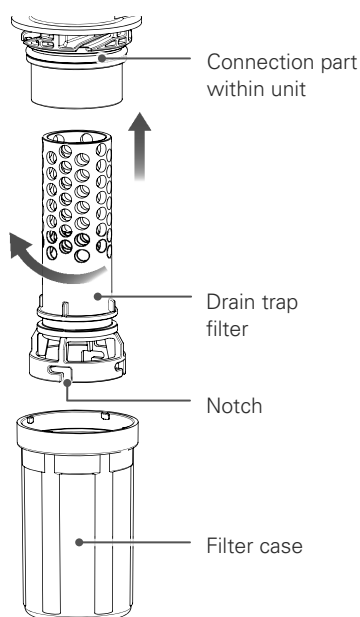

- ③ Discard the waste water inside the filter case.
- ④ Take apart the filter case and trap filter.  
While holding the filter case, turn the trap filter as far as it will go in the direction of the arrow and then pull it upward.
- ⑤ Rinse the filter case and drain trap filter in running water.

- ⑥ When cleaning is finished, combine the filter case and the trap filter as before.  
Align the protrusions within the filter case with the notches at the bottom end of the drain trap filter and insert. Next, rotate the filter case as far as it will go in the opposite direction to disassembly.

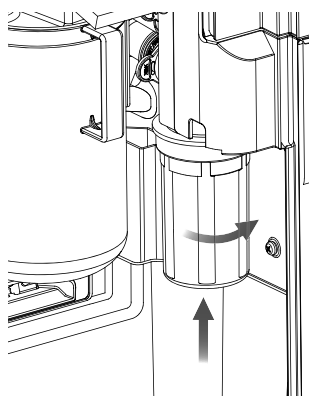

- ⑦ Attach the combined filter case and drain trap filter to the connection in the unit.  
Press the assembled drain trap against the connection part and turn in the direction of the arrow to attach.

Check that the filter case is securely fixed.

Be sure to install the drain trap filter. Problems such as clogging of the waste water pipeline and poor drainage may occur.

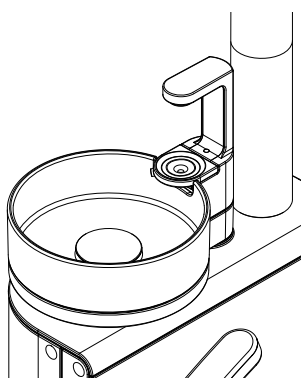

- ⑧ When installation is finished, close the unit door and allow about 2 cups of water to flow in the basin.  
This fills the drain trap with water and prevents bad odors coming from the waste water pipe.  
Check the surroundings of the drain trap for water leaks.

## 5.7.6 Cleaning the Oil Collector

### ⚠ CAUTION



Clean the inside of the oil collector at least once a month.

- Failure to do so may cause overflow of oil from the oil collector or other faults.

At least once a month, discard the oil collected in the oil collector on the underside of the tray.

Also check that the air turbine exhaust is normal.

Even at less than a month, discard the oil if it is above the level line on the oil cup.

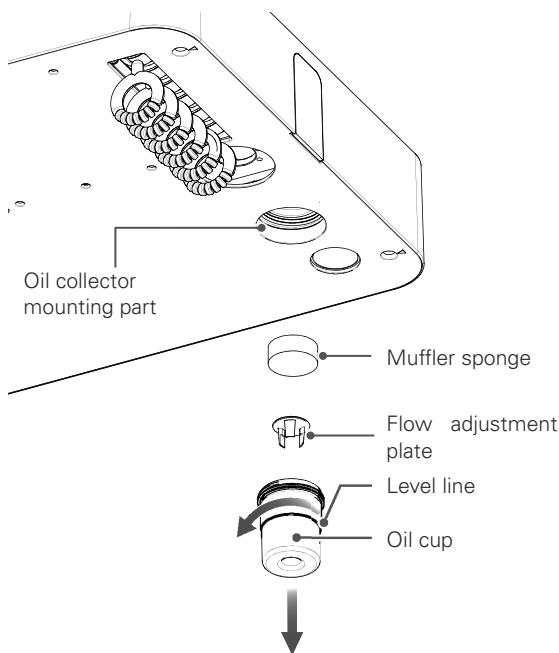

- ① Turn the oil cup in the direction of the arrow to remove it.  
During removal, take care not to spill the collected oil.
- ② Soak up the oil in the oil cup using paper etc. and discard it.
- ③ Remove the flow adjustment plate located in the oil cup.
- ④ Pull out the muffler sponge fitted in the oil collector mounting part in the tray.
- ⑤ Rinse the oil cup, flow adjustment plate, and muffler sponge in running water.  
After rinsing, remove all moisture from the surface.
- ⑥ Install by reversing the above procedure.  
Fit the muffler sponge into the oil collector mounting part on side of the tray.  
With the flow adjustment plate fitted in place, screw in the oil cup.
- ⑦ After installing the oil collector, check the condition of the air turbine exhaust.  
If exhaust air is not emitted, stop using the device, and consult a reseller or MORITA CORP. subsidiary.





If the O-ring at the tip of the air turbine tube is broken, water may accumulate in the oil collector in a short period of time.

If this happens, replace the O-ring with a new one.



## 5.8 Annual Maintenance

### 5.8.1 Sterapore Cartridge Replacement

 <b>WARNING</b>	
	<p>Do not bring fingers close to the electrical parts inside the piping pit and do not expose parts to water. Do not operate the chair when the piping pit is open.</p> <ul style="list-style-type: none"> <li>● Accidents such as an electric shock, short-circuit and pinching and damage/faults may occur.</li> </ul>
 <b>CAUTION</b>	
	<p>Be careful to avoid the following when handling sterapore cartridges.</p> <ol style="list-style-type: none"> <li>① Mixing up water and air cartridges</li> <li>② Misconnecting IN and OUT</li> <li>③ Disassembling cartridges</li> <li>④ Reconnecting used cartridges</li> <li>⑤ Using cartridges other than those normally connected to the mains water supply and or compressed air circuits</li> <li>⑥ Using cartridges other than products designated by us</li> </ol> <ul style="list-style-type: none"> <li>● Not only will it be impossible to achieve the desired effects, but it may cause water leaks and air leaks and damage the unit.</li> </ul>
	<p>Before removing the sterapore cartridge, be sure to relieve the pressure within the circuit by following the procedure in these instructions.</p> <ul style="list-style-type: none"> <li>● Forcibly removing it may lead to injury and other accidents.</li> </ul>
	<p>Be sure to always close the water supply valve and air supply valve before starting replacement.</p> <ul style="list-style-type: none"> <li>● Failure to do so may cause water/air leaks.</li> </ul>
	<p>Be sure replace the sterapore cartridge every year.</p> <p>If a deterioration in performance is seen at less than one year due to water quality fluctuations etc., promptly replace the sterapore cartridge.</p> <ul style="list-style-type: none"> <li>● Failure to replace the cartridge may cause water and air leaks due to a degradation in performance, pipeline clogging, pipeline foreign matter etc. or a fault.</li> </ul>
	<p>Securely connect the sterapore cartridge.</p> <ul style="list-style-type: none"> <li>● If the connection is incorrect or insufficient, a water leak/air leak/damage/fault may occur.</li> </ul>

Replace the sterapore cartridge once a year.

## ■ Removing the Pit Cover

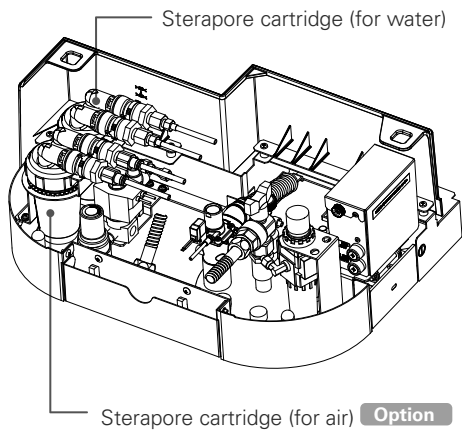
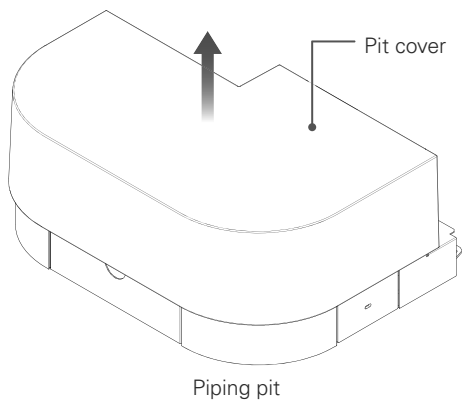
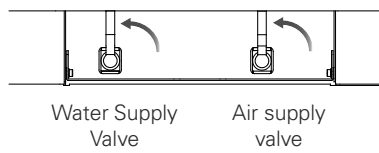

① Raise the chair to a position where the pit cover can be removed and turn the main switch OFF.

② Close the water supply valve and air supply valve by turning them in the direction of the arrow.

Expel water and air from the three-way syringe to relieve the internal pressure in the water and air circuits.

③ Lift off the pit cover of the piping pit.



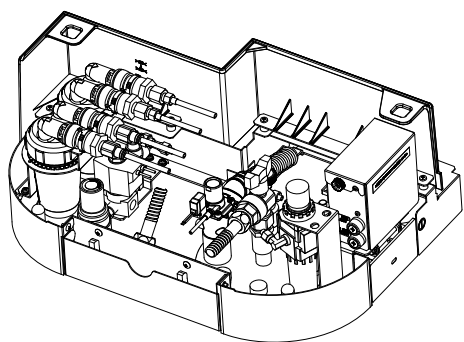

④ Position the sterapore cartridge in the pit as before.

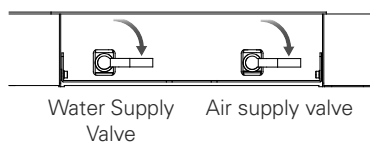

⑤ Turn the main switch ON.

⑥ Open the water supply valve and air supply valve by turning them in the direction of the arrows.

⑦ Expel water/air from the threeway syringe.

Check that water/air is being properly expelled and that there are no leaks around the one-touch joints.

⑧ Turn the main switch OFF and install the pit cover.

⑨ Turn the main switch ON again and check that there are nothing abnormal occurs in various operations.

When a sterapore cartridge for water is replaced, air is introduced into the water line. Operate the automatic filler, running the water until no more air is introduced.

## 5.9 Maintenance as Required

<b>⚠ WARNING</b>	
<b>!</b>	<p>Do not leave moisture, detergent, ethanol etc on the main unit surface or inside the device.</p> <p>Do not allow moisture to adhere inside and do not do anything that could cause water to enter the unit such as directly wetting the display panel, operation panel switches or automatic filler.</p> <p>In the event that water does adhere, turn the main switch OFF, wipe thoroughly with a dry cloth etc. and dry thoroughly before reuse.</p> <ul style="list-style-type: none"> <li>● Accidents such as fire due to a short circuit, discoloration/deterioration/malfunction/faults may occur.</li> </ul>
<b>⚠ CAUTION</b>	
<b>⊘</b>	<p>When cleaning each part of the main unit, do not use a cleaning agent other than the supplied cleaning agent (or neutral detergent).</p> <ul style="list-style-type: none"> <li>● If you use chemical wipes, cleaning products impregnated with chemicals or items containing cleansers besides disinfectant ethanol (benzene, thinners etc.), it may adversely affect the unit, causing discoloration, degradation and faults.</li> </ul> <p>Do not apply wax and solvents designed for use on floors to the housing/foot control etc.</p> <p>In the event that a product does adhere, wipe it off promptly.</p> <ul style="list-style-type: none"> <li>● If the product is left it may cause discoloration/deterioration/faults.</li> </ul> <p>When cleaning the main unit, do not spray water, cleaning agent etc. directly on the main switch.</p> <ul style="list-style-type: none"> <li>● This may cause a fault.</li> </ul>
<b>!</b>	<p>If chemicals adhere to resin parts such as the instrument holders or tray surfaces, wipe them off immediately using a soft cloth with a little disinfectant ethanol.</p> <p>Do not allow ethanol to enter inside the main unit.</p> <ul style="list-style-type: none"> <li>● Leaving chemicals adhering may cause discoloration or deterioration.</li> </ul>

### 5.9.1 Cleaning the Automatic Filler

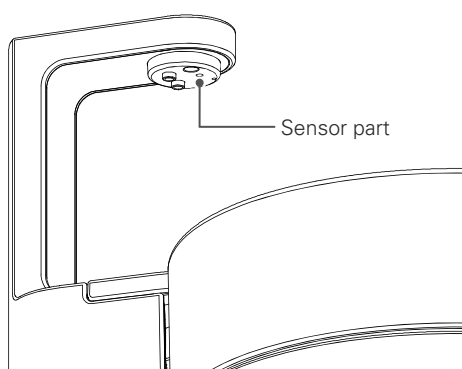



When cleaning the automatic filler, be careful not to allow foreign matter such as lint to enter into the notch in the sensor.  
Ingress of foreign matter may cause a malfunction.

### 5.9.2 Cleaning Other Parts

- ① Add water, the supplied cleaning agent, neutral detergent, or disinfectant ethanol to a soft cloth, sponge etc. and wipe it off.
- ② Then, wipe with a dry cloth, taking care not to leave any residual moisture or detergent.

## 6 Maintenance and Inspection

 <b>WARNING</b>	
	Carry out maintenance and inspection in order to use this product safely and comfortably. ● Failure to do so may cause a fault or unexpected accident.
	When reusing the unit after leaving it for a long period of time, always check that the main unit operates normally and safely before use. ● Failure to do so may cause a fault or unexpected accident.
	If you think there is a fault, check this according to “7. Troubleshooting” in these operation instructions and consult the local reseller or MORITA CORP. subsidiary. ● It is dangerous to disassemble, repair, or reconstruct this unit without permission.
	Regularly check and clean the circuit board (and earth) inside the chair to prevent dust from adhering. ● Accidents such as fire, electric shock etc. may occur.
	Do not perform maintenance checks on this product during patient treatment. ● Accidents and faults due to unforeseen circumstances/electric shock etc. may occur.

Since this product falls into the category of medical equipment requiring specialist maintenance and management, the medical facility should carry out maintenance and inspection (daily inspection and periodic maintenance inspection).

For instruments, operating lights, visible light irradiators etc., refer to the operation instructions and inspection list supplied with the product.

Parts list/technical data etc. for this product will be distributed at the request of repair companies. Contact your reseller or MORITA CORP. subsidiary.

### 6.1 Replacement of Consumable Parts

To maintain performance and ensure safety, replace consumable parts as set out in the following table.

When ordering and replacing consumable parts, contact your reseller or MORITA CORP. subsidiary. For the disposal methods of replaced parts, refer to “9. Medical Device Disposal” in these operation instructions.

When 10 years have elapsed after discontinuing production of this product, we may not be able to supply parts.

## 6.1.1 List of consumable parts

List of consumable parts			
No.	Part name	Replacement timing	Replacement method
1	Various filters · Basin catch and filter · Drain trap filter · Filter of vacuum filter · Water supply filter	When damage, contamination, abrasions or stretching is observed; When the performance level drops	Consult with your reseller or the nearest MORITA CORP. subsidiary.
2	Sterapore cartridge · for water · for air	After 1 year of use; When the performance level drops	Refer to "5.8.1 Sterapore Cartridge Replacement" pp. 141-144
3	Various O-rings, packing, diaphragms · O-ring for the drain trap · O-ring of vacuum filter · O-ring for the vacuum tank · O-ring for the vacuum syringe · O-ring for the saliva ejector · Valve plate for the vacuum tank waste water · Diaphragm for the control block	When damage, contamination, abrasions or stretching is observed; When the performance level drops	Consult with your reseller or the nearest MORITA CORP. subsidiary.
4	Various seats Seat, backrest and headrest's leather	When damage, contamination, abrasions is observed; When the performance level drops	Consult with your reseller or the nearest MORITA CORP. subsidiary
5	Various main tubes	When damage, contamination, abrasions is observed; When the performance level drops	Consult with your reseller or the nearest MORITA CORP. subsidiary
6	Various tubes for piping (Vacuum piping, etc.)	When damage, abrasions is observed; When the performance level drops	Consult with your reseller or the nearest MORITA CORP. subsidiary
7	Various fuses	When it blows	Consult with your reseller or the nearest MORITA CORP. subsidiary.
8	Lights	When it blows	Consult with your reseller or the nearest MORITA CORP. subsidiary.
9	Covers · Headrest cover · Contour seat cover <b>Option</b>	When damage, contamination, abrasions or stretching is observed; When the performance level drops	Consult with your reseller or the nearest MORITA CORP. subsidiary.
10	Various silicone products · Tray handle · Vial holder · Water supply tank lid · Flushing device adapter · Silicone tray sheet <b>Option</b>	When damage, contamination, abrasions or stretching is observed; When the performance level drops	Consult with your reseller or the nearest MORITA CORP. subsidiary.
11	Parts for autoclave sterilization	When damage, contamination, abrasions is observed; When the performance level drops	Consult with your reseller or the nearest MORITA CORP. subsidiary
12	Various disposable/paper products · Paper cups · Tops for paper cups · Tray paper	Every examination	Consult with your reseller or the nearest MORITA CORP. subsidiary.

<b>List of consumable parts</b>			
No.	Part name	Replacement timing	Replacement method
13	Tube lifter	When damage, contamination, abrasions or stretching is observed; When the performance level drops	Consult with your reseller or the nearest MORITA CORP. subsidiary.
14	Instrument holder	When damage, contamination, abrasions or stretching is observed; When the performance level drops	Consult with your reseller or the nearest MORITA CORP. subsidiary.
15	Muffler sponge for the oil collector	When damage, contamination, abrasions or stretching is observed; When the performance level drops	Consult with your reseller or the nearest MORITA CORP. subsidiary.
16	Flexible tube for drainage/suction	When damage, contamination, abrasions or stretching is observed; When the performance level drops	Consult with your reseller or the nearest MORITA CORP. subsidiary.
17	Syringe case, nozzle of the threeway syringe	When damage/abrasion is seen; When the performance level drops	Consult with your reseller or the nearest MORITA CORP. subsidiary.
18	Various vacuum syringe nozzles, various tips	When damage/abrasion is seen; When the performance level drops	Consult with your reseller or the nearest MORITA CORP. subsidiary.
19	Various nozzles and tips of saliva ejector nozzle	When damage/abrasion is seen; When the performance level drops	Consult with your reseller or the nearest MORITA CORP. subsidiary.
20	Oil for hydraulic motors	When deterioration/evaporation occurs	Consult with your reseller or the nearest MORITA CORP. subsidiary.
21	MORITA multispray	When it runs out	Consult with your reseller or the nearest MORITA CORP. subsidiary.
22	Batteries	When exhausted	Replace with a new battery.



## 6.1.2 Parts Replacement for Threeway Syringe

### LED Replacement for light-equipped model

<b>⚠ WARNING</b>	
<b>!</b>	Turn off the main switch before replacing the LED to avoid the risk of electric shocks or burns.
<b>⊘</b>	Do not shine the LED directly into the eye. This could impair one's eyesight.
<b>⚠ CAUTION</b>	
<b>⊘</b>	Avoid getting burned by the LED or the LED cover, which can get quite hot. Wait for them to cool off before replacing the LED.
<b>⊘</b>	Make sure the nozzle click into place securely; otherwise, air pressure could blow it off the syringe.

- 1** Take the nozzle off the syringe and remove the LED cover by turning it in the direction indicated by the arrow in the illustration.



- 2** Take the LED out of its socket.



- 3** Line up the ridges and grooves and push the new LED straight into place.

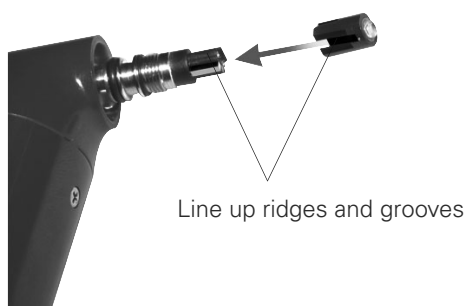

- 4** Replace the LED cover. Slide the nozzle in until it clicks into place. Connect the syringe to its tube and see if the light works properly.



Water or air might leak if the LED cover is not tightened up properly.

## 6.2 Daily Inspection by the User

Inspect the device according to the table below and check that there are no abnormalities/defects.

Carry out before use (startup inspection) and after use (shutdown inspection).

If an issue discovered at inspection is beyond the scope of the actions in the table or if any abnormality is found, consult your reseller or nearest MORITA CORP. subsidiary.

### 6.2.1 Startup Inspection

Check the contents of the table below before use.

No.	Inspection item	Action	Reference page
1	Is there rattling or looseness in the body/light/arm/unit/seat/instrument holder?	Adjust and tighten.	pp.10-13, pp.38-39, p.44, p.72, p.80
2	Is there anything under the seat interfering with operation?	Make enough space around the seat and remove impediments, if any.	p.21
3	Can the chair be stopped correctly?	Make sure that stopping (stop operation and operation of the various safety switches) can be performed normally.	p.21, p.29
4	Are there any leaks in the water supply line/air/sterapore cartridge/drain trap/water supply device/main tubes (abnormalities such as leak marks, dripping noises)?	Check each part and correct connections.	p.9, p75, p.139, p.145
5	Are there any abnormalities such as rubbing, dislocation, tilting, noises etc. in the main unit housing (base housing/pit housing)?	With the chair raised, check visually that there are no abnormalities.	p.26
6	Do the foot control, display panel, and instruments (air turbine, motor, ultrasonic scaler, etc.) operate correctly?	Carry out trial operation to see if there are abnormalities in the switches/display/operation etc. Also check option specifications such as clean air system.	p.14, p.23, p.27, p.46, p.48
7	Can the automatic filler/bowl washing/chair lock etc. be used properly?	Ensure that they can be used correctly and that the amount of adjustment/operation time is appropriate.	p.30, pp.77-79

### 6.2.2 Shutdown Inspection

Check after use.

No.	Inspection item	Action	Reference page
1	Is the main switch OFF?	Turn the main switch OFF.	p.17

## 6.3 Regular Maintenance Inspection

According to the Ordinance for Enforcement of the Medical Practitioners' Act and the notification from the Director of the Ministry of Health, Labor and Welfare, maintenance and inspection is designated, in principle, as work performed by medical institutions. Please carry out an inspection every 6 months in accordance with the regular maintenance and inspection list set out in the separately attached to the Warranty Card.

If any abnormality is found, please contact your reseller or MORITA CORP. subsidiary.

Note also that the inspection can be outsourced. For details, please contact your reseller or MORITA CORP. subsidiary.

### 6.3.1 Maintenance and Inspection by the User

Have the contractor check the items listed in the table below.

No.	Content of inspection
1	Movement of the seat and backrest (manual operation)
2	Movement of the seat and backrest (automatic operation)
3	Stop automatic operation and safety lock
4	Headrest operation
5	Mounting condition of seat and backrest
6	Automatic filler
7	One-touch connectors (water supply/air supply)
8	Sterapore cartridge
9	Air turbine handpiece connection
10	Operation of and air pressure supply to the air turbine handpiece
11	Air turbine hand piece circuit and water flow/lighting conditions
12	Micromotor connection and operation
13	Micromotor circuit and water flow/lighting conditions
14	Connection and operation of vacuum syringe and saliva ejector
15	Threeway syringe connection and operation

### 6.3.2 Outsourcing Maintenance and Inspection to a Contractor

Have the contractor check the items listed in the table below.

No.	Content of inspection
1	Power supply voltage for device operation
2	Floor and fixing condition
3	State of electric circuit wiring
4	State of piping/tubes
5	Assembly condition of screws and exterior
6	Contamination within the unit
7	Condition of hydraulic circuits
8	Operating light power-supply voltage

### 6.4 After-sales Service and Contact Information

If after-sales service is required, please contact your local dealer.

## 7 If Problems Arise

### 7.1 Items to be Checked before Requesting Repair

If problems occur during use, refer to the table below, check and take action.

If an improvement is not achieved even when the following checks are performed and actions are taken, or if any abnormality other than those in the description is found, please stop using the device and consult with your reseller or nearest MORITA CORP.

Symptoms	Possible cause	Checks/actions	Reference page
Even with the main switch ON, there is no power	The room breaker is OFF	Switch ON the circuit breaker on the interior distribution board.	—
	Fuse has blown	Request a fuse replacement.	p.157
The seat and backrest do not move	A safety switch has been triggered	Remove impediments.	p.21
	A temporary abnormality due to unforeseen circumstances such as electrical noise	Briefly turn the main switch OFF and turn it ON again.	pp.16-17
The backrest moves when the foot pedal is stepped on	A safety switch has been triggered	Remove impediments.	p.21
It cannot be operated	Chair lock is in operation	Release the chair lock switch.	p.30
Nothing happens when the panel switch is pressed	Two or more switches have been pressed simultaneously	Be sure to press switches one at a time.	p.23
The micromotor does not work	Fuse has blown	Replace the motor fuse.	p.157
Doctor-side instruments do not work	HP LOCK is in operation	Check the status of the HP LOCK and release the lock if necessary.	p.88
The vacuum syringe/saliva ejector does not suck or suction is weak	The vacuum filter/vacuum tank are contaminated.	Clean them.	p.128, p.136
	The vacuum filter/vacuum tank are improperly installed and there is a gap in the connection	Install it correctly.	p.128, p.136
	Dirt in vacuum tank may cause a bad water flow or clog. At this time, the float switch in vacuum tank will work to stop suction.	Clean the vacuum tank.	pp.136-137
	If you suck a large amount of water at one time while cleaning the vacuum tank, the float switch in vacuum tank will work to stop suction for the sudden rise of water level.	After exhausting all of water in the vacuum tank, restart vacuum suction again.	—
Basin does not drain properly	The basin filter/drain trap is dirty.	Clean them.	p.129, pp.139-140

## 7.2 Error Display

If the following error messages appear on the display panel during use, refer to the table below, confirm the problem and take the appropriate action.

If an improvement is not achieved even when the following checks are performed and actions are taken, or if any abnormality other than those in the description is found, please stop using the device and consult with your reseller or nearest MORITA CORP.



Display	Possible cause	Checks/actions
SAFETY SW SEAT UP	The safety switch of assistant-side arm was activated when the chair moved up. (stand unit type only)	Check the condition of the assistant-side arm.
SAFETY SW SEAT DOWN	The safety switch was activated when the chair was lowered.	Check the condition of the assistant-side arm, backrest, foot support, and piping pit.
SAFETY SW BACKREST UP	The leg support underside safety switch was activated when the backrest was made upright.	Check the state of the underside of the leg support.
SAFETY SW BACKREST DOWN	The safety switch was activated when the backrest was tilted.	Check the state of the backrest.
SAFETY SW TRAY	The safety switch was activated when the auxiliary tray moves up.	remove the load.
CHAIR ERROR 1 SERVO	The hydraulic servo motor is faulty.	Stop using and request inspection/repair.
CHAIR ERROR 2 CONTIN OP PROTEC	The protection circuit was triggered during continuous operation.	Stop using it and leave it for a while.
SAFETY LOCK SW BASIN	The chair moved when the basin moved to the patient's side.	Return the basin to the original position.
CHAIR LOCK 1 LOCK SW	The chair moved when the chair lock switch was pressed.	Release the chair lock switch.
CH COMM ERROR	Chair PCB control is faulty.	Stop using and request inspection/repair.
FOOT COMM ERROR	Foot PCB control is faulty.	Check the foot controller has fallen or tilted. If it does not return, request inspection/ repair.
SERVO ERROR 1	HS variable speed mechanism fault.	Stop using and request inspection/repair.
SERVO ERROR 2	HS variable speed mechanism fault.	Stop using and request inspection/repair.
VR ERROR	A potentiometer in the foot control is faulty.	Stop using and request inspection/repair.
ERR LS OVERHEAT	The protection circuit was triggered during the micromotoer operation.	Stop using it and leave it for a while.

## 7.3 Fuse

<b>⚠ WARNING</b>	
<b>!</b>	<p>When replacing the fuse, always turn the main switch OFF.</p> <ul style="list-style-type: none"> <li>● Failure to do so may result in an accident such as an electric shock or a fault.</li> </ul>
<b>!</b>	<p>If a fuse blows, there may be a problem with the electric wiring, so promptly consult your reseller or nearest MORITA CORP. subsidiary for an inspection.</p> <ul style="list-style-type: none"> <li>● If the unit continues to be used as is, an accident caused by electric leakage etc. or failure may occur.</li> </ul>
<b>⚠ CAUTION</b>	
<b>!</b>	<p>When replacing the fuse, be sure to use a fuse of the same rating, same characteristics, and same type as the IEC standard.</p> <ul style="list-style-type: none"> <li>● Using a substitute items (such as wire) could result in a fire due to overheating of the electric wires.</li> </ul>

Fuse replacement should be performed by a technical service representative.

Ask your reseller or nearest MORITA CORP. subsidiary.

### ■ When use is interrupted, after completion of treatment

When the fuse blows, replace it with a new one using the following procedure.

Use a medium Phillips screwdriver.

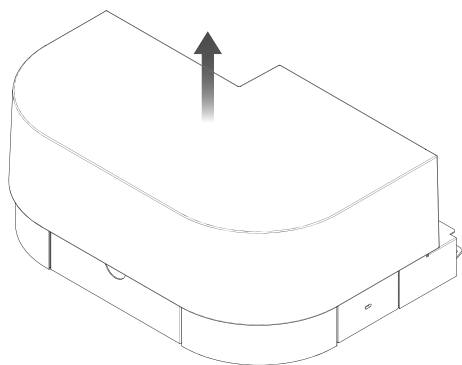

- ① Make the chair go up.
- ② Turn the main switch OFF. Lift the pit cover up and remove it.
- ③ Replace the fuse in the fuse holder.

Remove the cap of the fuse holder (15A uses a medium-sized Phillips screwdriver), extract the blown fuse, and replace it with a new one.

Be sure not to confuse the rating, characteristics, and model of fuse.

- ④ Installation is completed by installing each part in reverse order.

If the fuse blows again, the electric wiring may be abnormal. At this time, stop using the device, turn the main switch OFF and ask your reseller or the nearest MORITA CORP. subsidiary for an inspection.

\*1: conditions vary depending on specifications. Follow the main unit notes.

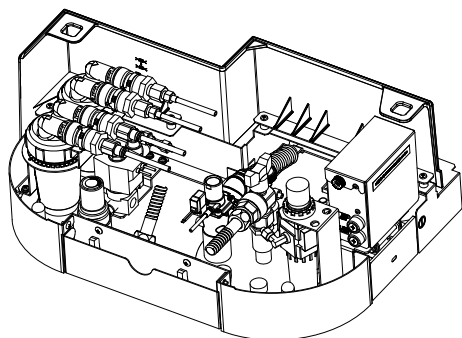

---

## 8 Warranty and Repair

---

### 8.1 Warranty of this Product

In the event of a malfunction following correct use in accordance with the operation instructions, the product will be repaired or replaced free of charge within the warranty period based on the conditions and scope described in the separate Warranty Card.

Read the "Content of Warranty" on the back of the Warranty Card for details.

### 8.2 Warranty Card

When purchasing this unit, fill out the prescribed details on the separate Warranty Card, give it to the reseller, and keep the warranty in a safe place.



## 8.3 Repair

### 8.3.1 Before Requesting a Repair

Please check the symptoms/condition according to "7.Troubleshooting" in these operation instructions before requesting a repair.

### 8.3.2 Requesting a Repair

#### ■ Repair request within the warranty period

Attach the Warranty Card, and send the request to your reseller or nearest MORITA CORP. subsidiary. We will respond free of charge.

You will bear the actual cost of parts not covered by the warranty such as consumable parts.

#### ■ Repair request outside the warranty period

Consult your reseller or nearest MORITA CORP. subsidiary. If the performance can be maintained/restored by repair/parts exchange, we will apply a charge.

### 8.3.3 Spare Part Maintenance Period

The manufacturer's stores spare parts for a period 10 years after discontinuation of the product. It may not be possible to respond to repair requests/parts orders after this period has elapsed.

---

## 9 Disposal of the Medical Device

---

### 9.1 Disposal of This Product

This product and accompanying parts/consumable parts fall into the category of medical devices. Please observe the disposal regulations in the applicable area.

Check with a dentist or physician that the infectious waste from the medical device is in a non-infectious state and ensure that the medical institution consigns industrial waste material and industrial waste subject to special control to a processing company qualified to deal with it.

Follow regional provisions for waste material and packaging materials that are not regarded as infectious waste.

Prior to disposal of the cordless foot control, remove the batteries from the foot control.

# 10 General Information









## 10.1 Specifications

Name	signo T500	
Non-proprietary name	Dental Treatment Unit	
Manufacture and marketing	J. MORITA TOKYO MFG. CORP. J. MORITA MFG. CORP. (WS10-O-LD)	
Model	TUA60 (chair mount type)/TUA70 (stand unit type)	
Intended purpose	This product, installed in a dental clinic, locates a patient to a position for medical examination, delivers air, water, vacuum, and electricity to dental equipment which is intended to be attached and operates it, and supplies and drains water for rinsing out patient's mouth.	
Power-supply voltage	220 / 230 / 240V AC	
Power supply input	1 kVA	
Frequency	50/60Hz	
Input pressure	0.39-0.78MPa (air) 0.20-0.59MPa (water)	
Vibration mode	Longest 50 seconds ON / shortest 5 minutes OFF (hydraulic motor)	
Protect against electrical shock	Class I Equipment Permanently installed devices Type B applied part * However, connected devices follow the classification of each device.	
Applied parts	Type B(micromoter,air turbine) Type BF(ultrasonic scaler)	
Protection from harmful ingress of water or ingress of solids.	IPX1 (foot control)	
Seat type	contour type/foot support type	
Seat pad height (from the floor)	Lowest position 400mm±10mm Highest position 800mm±10mm	
Backrest angle (relative to the horizontal)	Most upright 78±2° Most tilted 2±2°	
Weight	TUA60: about 260kg / TUA70: about 280kg	
Maximum loading mass	150kg (Seat 89kg, Backrest 61kg)	
Seat lifting system	Hydraulic electrical vertical lift	
Threeway syringe water jet/spray amount	30mL/15sec or more (WS97) 60mL/15sec or more (WS100 / WS100LD,WS10-O-LD)	
Vacuum syringe suction volume	140 L/min or more (Suction motor performance: equivalent to 15 kPa at low suction 0.17 m <sup>3</sup> / min ~ equivalent to 17.64 kPa at high suction 0.6 m <sup>3</sup> / min ) <sup>Note 1</sup>	
Vacuum syringe vacuum	-8.0 kPa (static pressure) or less (suction motor performance: flow 900 L/min, suction pressure 14.0 kPa) <sup>Note 1</sup>	
Maximum load power	Warmer tank: 190W threeway syringe: 20W	
Maximum permitted load	Foot control pedal: 1350 N	
EMC specifications	Conforms to IEC60601-1-2: 2014	
Cordless foot control	Frequency band	ISM 2.4 GHz
	Radiation ability	4.5 dBm e.i.r.p (Max 2.8mW)
	Supply	Primary battery
	Battery type / quantity	AA alkaline batteries / 3 pieces

[Please note that specifications and appearance may change without prior notice for product improvement purposes.]

Note 1: Low suction: equivalent to EV- 12- II of J MORITA CORP. / high suction: equivalent to TCS- 1.5 MAX of TOKYO GIKEN,INC.



## 10.2 Symbols

	Manufacturer		Alternating current
	Date of manufacture		Type B applied part
	Serial number		Type BF applied part
	Conforms with the WEEE Directive		ON/OFF (push-push)
<b>IP X 1</b>	IP code Liquid ingress protection; Level 1		Refer to instruction manual/booklet

## 10.3 EMC Electromagnetic Compatibility EMC

TUA60/TUA70 conforms to electromagnetic compatibility in IEC 60601-1-2:2014.

The following sentences are “Guidelines and a Declaration of Manufacturers and Distributors” required as attached document according to IEC 60601-1-2:2014 on electromagnetic compatibility.

 <b>WARNING</b>	
	This product requires precautions related to EMC and it is necessary to install and use the product according to the EMC information described in these operation instructions.
	Portable and mobile RF communication equipment may affect this product.
	Portable RF communications equipment should be used no closer than 30cm(12 inches) to any part of the TUA60/TUA70, otherwise, degradation of the performance this equipment could result.
	If accessories other than those sold as replacement parts by the marketing authorization holder are used, performance of this product may deteriorate regarding EMC.
	The use of accessories and cables other than those specified, with the exception of replacement parts sold by J. MORITA TOKYO MFG CORP. may result in increased emissions or decreased immunity of the TUA60/TUA70.
	Where possible this product should not be placed adjacent to other equipment, and should not be use with other equipment. If use with other equipment is required, only proceed after observing that the unit and other equipment work properly together.

<b>EMISSION</b>		
<b>Emissions Test</b>	<b>Compliance</b>	<b>environment</b>
RF emission CISPR 11	Group 1 Class B	Professional healthcare facility environment
Harmonic distortion IEC61000-3-2	Class A	Professional healthcare facility environment
Voltage fluctuation and Flicker IEC 61000-3-3	Complies	Professional healthcare facility environment

<b>IMMUNITY</b>			
<b>Phenomenon</b>	<b>Basic EMC standard or test method</b>	<b>IMMUNITY TEST LEVELS</b>	<b>Environment</b>
Electrostatic Discharge (ESD)	IEC 61000-4-2	±8 kV contact ±2, ±4, ±8, ±15kV air	Professional healthcare facility environment
Radiated RF EM fields	IEC 61000-4-3	3 V/m 80 MHz-2.7 GHz 80% AM at 1kHz	Professional healthcare facility environment
Proximity fields from RF wireless communications equipment	IEC 61000-4-3	See Attachment 1	Professional healthcare facility environment
Electrical fast transient / burst	IEC 61000-4-4	±2.0 kV power supply 100 kHz repetition frequency	Professional healthcare facility environment
Surges Line-to-line	IEC 61000-4-5	±0.5, ±1 kV	Professional healthcare facility environment
Surges Line-to-ground	IEC 61000-4-5	±0.5, ±1, ±2kV	Professional healthcare facility environment
Conducted disturbances Induced by RF fields	IEC 61000-4-6	3V 0,5 MHz – 80 MHz 6V in ISM bands Between 0,15MHz and 80 MHz 80% AM at 1 kHz	Professional healthcare facility environment
RATED power frequency magnetic fields	IEC 61000-4-8	30 A/m 50 Hz or 60Hz	Professional healthcare facility environment
Voltage dips	IEC 61000-4-11	0% UT :0.5 cycle At 0°, 45°, 90°, 135°, 180°, 225°, 270°and 315°	Professional healthcare facility environment
		0% UT: 1 cycle and 70% UT:25/30 cycles Single phase: at 0°	Professional healthcare facility environment
Voltage interruptions	IEC 61000-4-11	0% UT:250/300 cycle	Professional healthcare facility environment

Attachment 1.

**Test specifications for ENCLOSURE PORT IMMUNITY to  
RF wireless communications equipment**

<b>Test Frequency (MHz)</b>	<b>Band <sup>a)</sup> (MHz)</b>	<b>Service <sup>a)</sup></b>	<b>Modulation <sup>b)</sup></b>	<b>Maximum Power (W)</b>	<b>Distance (M)</b>	<b>IMMUNITY TEST LEVEL (V/m)</b>
385	380- 390	TETRA 400	Pulse modulation <sup>b)</sup> 18Hz	1,8	0,3	27
450	430- 470	GMRS 460, FRS 460	FM <sup>c)</sup> ± 5kHz deviation 1 kHz sine	2	0,3	28
710	704- 787	LTE Band 13, 17	Pulse modulation <sup>b)</sup>	0,2	0,3	9
745						
780			217 Hz			
810	800- 960	GSM 800/900, TETRA 800, iDEN 820, CDMA 850, LTE Band 5	Pulse modulation <sup>b)</sup>	2	0,3	28
870						
930			18 Hz			
1 720	1 700- 1 990	GSM 1800; CDMA 1900; GSM 1900; DECT; LTE Band 1, 3, 4, 25; UMTS	Pulse modulation <sup>b)</sup>	2	0,3	28
1 845						
1 970			217 Hz			
2 450	2 400- 2 570	Bluetooth, WLAN, 802. 11 b/g/n, RFID 2450, LTE Band 7	Pulse modulation <sup>b)</sup> 217 Hz	2	0,3	28
5 240	5 100- 5 800	WLAN 802.11 a/n	Pulse modulation <sup>b)</sup>	0,2	0,3	9
5 500						
5 785			217 Hz			

NOTE If necessary to achieve the IMMUNITY TEST LEVEL, the distance between the transmitting antenna and the ME EQUIPMENT or ME SYSTEM may be reduced to 1 m. The 1 m test distance is permitted by IEC 61000-4-3.

<sup>a)</sup> For some services, only the uplink frequencies are included.

<sup>b)</sup> The carrier shall be modulated using a 50 % duty cycle square wave signal.

<sup>c)</sup> As an alternative to FM modulation, 50 % pulse modulation at 18 Hz may be used because while it does not represent actual modulation, it would be worst case.

Basic performance: none

Intended behavior

Cable length

Main tube: about 1.5m

Foot control: about 700 mm

Three-way Syringe Output: Water and Spray: 30mL / 15sec., minimum

Vacuum Syringe Performance: Volume: 90 L / min., minimum

It depends on the vacuum motor.

(Reference value)

Volume: 140 L / min., minimum

(with EV-12 Type II)

Diagnostic and Imaging Equipment



Treatment Units



Handpieces and Instruments



Endodontic Systems



Laser Equipment



Laboratory Devices



Educational and Training Systems



Auxiliaries



Sales Division

**J. MORITA CORP.**

Osaka Head Office 3-33-18, Tarumi-cho, Suita City, Osaka Japan 564-8650 Tel: +81. 6. 6380 2525  
Tokyo Head Office 2-11-15, Ueno Taito-ku, Tokyo Japan 110-8513 Tel: +81. 3. 3834 6161

Manufacturer

**J. MORITA TOKYO MFG. CORP.**

Main Factory Komuro 7129, Ina-machi, Kitaadachi-gun, Saitama Japan 362-0806 Tel: +81. 48. 723 2621

Morita Global Site: [www.morita.com](http://www.morita.com)

More Infos about Products: [www.dental-plaza.com](http://www.dental-plaza.com)

Please note that specifications and appearance may change without prior notice for product improvement purposes.

The company name and product names mentioned are trademarks, or registered trademarks of J. MORITA CORP. and J. MORITA TOKYO MFG. CORP.

As the color of the product is printed, it may differ from the actual color.

Some optional equipment is included.